



Owner's Manual

For professional use only

Airless Spray Technology

Do not use this equipment before reading this manual!

840i Airless Sprayer



Model Number:

- | | |
|----------------------------|----------------|
| High Rider Bare | 800-130 |
| High Rider Complete | 800-131 |
| Low Rider Bare | 800-132 |
| Low Rider Complete | 800-133 |

NOTE: This manual contains important warnings and instructions. Please read and retain for reference.



Important Safety Information • Read all safety information before operating the equipment. Save these instructions.



This symbol indicates a hazardous situation, which, if not avoided could result in death or serious injury.



To reduce the risks of fire or explosion, electrical shock and the injury to persons, read and understand all instructions included in this manual. Be familiar with the controls and proper usage of the equipment.

HAZARD: INJECTION INJURY

A high pressure paint stream produced by this equipment can pierce the skin and underlying tissues, leading to serious injury and possible amputation. See a physician immediately.



DO NOT TREAT AN INJECTION INJURY AS A SIMPLE CUT! Injection can lead to amputation. See a physician immediately.

The maximum operating range of the sprayer is 3300 PSI / 228 BAR fluid pressure.

PREVENTION:

- NEVER aim the gun at any part of the body.
- Do not aim the gun at, or spray any person or animal.
- NEVER allow any part of the body to touch the fluid stream. DO NOT allow body to touch a leak in the fluid hose.
- NEVER put your hand in front of the gun. Gloves will not provide protection against an injection injury.
- ALWAYS lock the gun trigger, shut the pump off, and release all pressure before servicing, cleaning the tip or guard, changing tip, or leaving unattended. Pressure will not be released by turning off the motor. The PRIME/SPRAY valve or pressure bleed valve must be turned to their appropriate positions to relieve system pressure. Refer to the PRESSURE RELIEF PROCEDURE described in this manual.
- ALWAYS keep the tip guard in place while spraying. The tip guard provides some protection but is mainly a warning device.
- ALWAYS remove the spray tip before flushing or cleaning the system.
- Paint hose can develop leaks from wear, kinking and abuse. A leak can inject material into the skin. Inspect the hose before each use. Do not use hose to lift or pull equipment.
- NEVER use a spray gun without a working trigger lock and trigger guard in place.
- All accessories must be rated at or above 3300 PSI / 228 BAR. This includes spray tips, guns, extensions, and hose.
- Do not leave the unit energized or under pressure while unattended. When the unit is not in use, turn off the unit and relieve the pressure in accordance with the PRESSURE RELIEF PROCEDURE described in this manual.
- Verify that all connections are secure before operating the unit. Unsecured parts may eject at great force or leak a high pressure fluid stream causing severe injury.
- Always engage the trigger lock when not spraying. Verify the trigger lock is functioning properly.

NOTE TO PHYSICIAN:

Injection into the skin is a traumatic injury. It is important to treat the injury as soon as possible. DO NOT delay treatment to research toxicity. Toxicity is a concern with some coatings injected directly into the blood stream. Consultation with a plastic surgeon or reconstructive hand surgeon may be advisable.

HAZARD: HAZARDOUS VAPORS

Paints, solvents, insecticides, and other materials can be harmful if inhaled or come in contact with the body. Vapors can cause severe nausea, fainting, or poisoning.



PREVENTION:

- Use a respirator or mask if vapors can be inhaled. Read all instructions supplied with the mask to be sure it will provide the necessary protection.
- Wear protective eyewear.
- Wear protective clothing as required by coating manufacturer.



HAZARD: EXPLOSION OR FIRE

Solvent and paint fumes can explode or ignite. Property damage and/or severe injury can occur.



PREVENTION:

- Provide extensive exhaust and fresh air introduction to keep the air within the spray area free from accumulation of flammable vapors. Solvent and paint fumes can explode or ignite.
- Do not spray in a confined area.
- Avoid all ignition sources such as static electric sparks, open flames, pilot lights, electrical appliances, and hot objects. Connecting or disconnecting power cords or working light switches can make sparks. Paint or solvent flowing through the equipment is able to result in static electricity.
- Do not smoke in spray area.
- Fire extinguisher must be present and in good working order.
- Place pump at least 25 feet (7.62 meters) from the spray object in a well ventilated area (add more hose if necessary). Flammable vapors are often heavier than air. Floor area must be extremely well ventilated. The pump contains arcing parts that emit sparks and can ignite vapors.
- The equipment and objects in and around the spray area must be properly grounded to prevent static sparks.
- Keep area clean and free of paint or solvent containers, rags and other flammable materials.
- Use only conductive or grounded high pressure fluid hose. Gun must be grounded through hose connections.
- For electric units — power cord must be connected to a grounded circuit.
- Always flush unit into a separate metal container, at low pump pressure, with spray tip removed. Hold gun firmly against side of container to ground container and prevent static sparks.
- Follow the material and solvent manufacturer's warnings and instructions. Know the contents of the paints and solvents being sprayed. Read all Material Safety Data Sheets (MSDS) and container labels provided with the paints and solvents. Follow the paint and solvent manufacturer's safety instructions.
- Use extreme caution when using materials with a flashpoint below 70°F (21°C). Flashpoint is the temperature that a fluid can produce enough vapors to ignite.
- Plastic can cause static sparks. Never hang plastic to enclose a spray area. Do not use plastic drop cloths when spraying flammable materials.
- Use lowest possible pressure to flush equipment.
- Do not spray onto pump assembly.





Important Safety Information • Read all safety information before operating the equipment. Save these instructions.

HAZARD: EXPLOSION HAZARD DUE TO INCOMPATIBLE MATERIALS



Will cause property damage or severe injury.

PREVENTION:

- Do not use materials containing bleach or chlorine.
- Do not use halogenated hydrocarbon solvents such as bleach, mildewcide, methylene chloride and 1,1,1 - trichloroethane. They are not compatible with aluminum.
- Contact your coating supplier about the compatibility of material with aluminum.

HAZARD: GENERAL

Can cause severe injury or property damage.

- Read all instructions and safety precautions before operating equipment.
- Follow all appropriate local, state, and national codes governing ventilation, fire prevention, and operation.
- The United States Government Safety Standards have been adopted under the Occupational Safety and Health Act (OSHA). These standards, particularly part 1910 of the General Standards and part 1926 of the Construction Standards should be consulted.
- Use only manufacturer authorized parts. User assumes all risks and liabilities when using parts that do not meet the minimum specifications and safety requirements of the pump manufacturer.
- All hoses, fittings, and filter parts must be secured before operating spray pump. Unsecured parts can eject at great force or leak a high pressure fluid stream causing severe injury.
- Before each use, check all hoses for cuts, leaks, abrasion or bulging of cover. Check for damage or movement of couplings. Immediately replace the hose if any of these conditions exist. Never repair a paint hose. Replace it with another grounded high-pressure hose.
- Do not kink or over-bend the hose. Airless hose can develop leaks from wear, kinking and abuse. A leak can inject material into the skin.
- Do not expose the hose to temperatures or pressures in excess of those specified by manufacturer.
- Do not spray outdoors on windy days.
- Wear clothing to keep paint off skin and hair.
- Do not operate or spray near children. Keep children away from the equipment at all times.
- Do not overreach or stand on an unstable support. Keep effective footing and balance at all times.
- Use lowest possible pressure to flush equipment.
- Stay alert and watch what you are doing.
- Do not operate the unit when fatigued or under the influence of drugs or alcohol.
- For electric units — Always unplug cord from outlet before working on equipment.
- Do not use the hose as a strength member to pull or lift the equipment.
- Do not lift by cart handle when loading or unloading.

Grounding Instructions

This product must be grounded. In the event of an electrical short circuit, grounding reduces the risk of electric shock by providing an escape wire for the electric current. This product is equipped with a cord having a grounding wire with an appropriate grounding plug. The plug must be plugged into an outlet that is properly installed and grounded in accordance with all local codes and ordinances.



Improper installation of the grounding plug can result in a risk of electric shock.



If repair or replacement of the cord or plug is necessary, do not connect the green grounding wire to either flat blade terminal. The wire with insulation having a green outer surface with or without yellow stripes is the grounding wire and must be connected to the grounding pin.

Check with a qualified electrician or serviceman if the grounding instructions are not completely understood, or if you are in doubt as to whether the product is properly grounded. Do not modify the plug provided. If the plug will not fit the outlet, have the proper outlet installed by a qualified electrician.

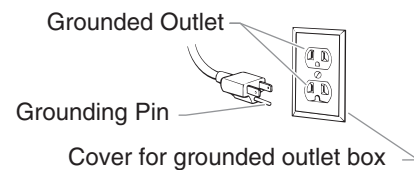

IMPORTANT: Use only a 3-wire extension cord that has a 3-blade grounding plug and a 3-slot receptacle that will accept the plug on the product. Make sure your extension cord is in good condition. When using an extension cord, be sure to use one heavy enough to carry the current your product will draw. An undersized cord will cause a drop in line voltage resulting in loss of power and overheating. A 12 gauge cord is recommended. If an extension cord is to be used outdoors, it must be marked with the suffix W-A after the cord type designation. For example, a designation of SJTW-A would indicate that the cord would be appropriate for outdoor use.

Table of Contents

- Safety Precautions2
 - Français14
 - Español16
- General Description4
- Operation4
 - Setup4
 - Preparing to Paint5
 - Painting5
 - Electronic Pressure Control Indicators5
 - Pressure Relief Procedure6
- Spraying6
 - Spraying Technique6
 - Practice7
- Cleanup7
- Maintenance7
 - General Repair and Service Notes8
 - Replacing the PRIME/SPRAY Valve8
 - Replacing the Filters8
 - Replacing the Motor Assembly9
 - Replacing the Gears9
 - Replacing the Transducer10
 - Servicing the Fluid Section10
- Troubleshooting12
- Parts Listings18
 - Main Assembly18
 - Drive Assembly19
 - Fluid Section Assembly20
 - High Rider Cart21
 - Filter Assembly21
 - Siphon Set Assembly (low rider)22
 - Labels22
 - Low Rider Assembly22
 - PRIME/SPRAY Assembly23
 - Electrical Schematic23
 - Accessories23
- Warranty24

General Description

This airless sprayer is a precision power tool used for spraying many types of materials. Read and follow this instruction manual carefully for proper operating instructions, maintenance, and safety information.

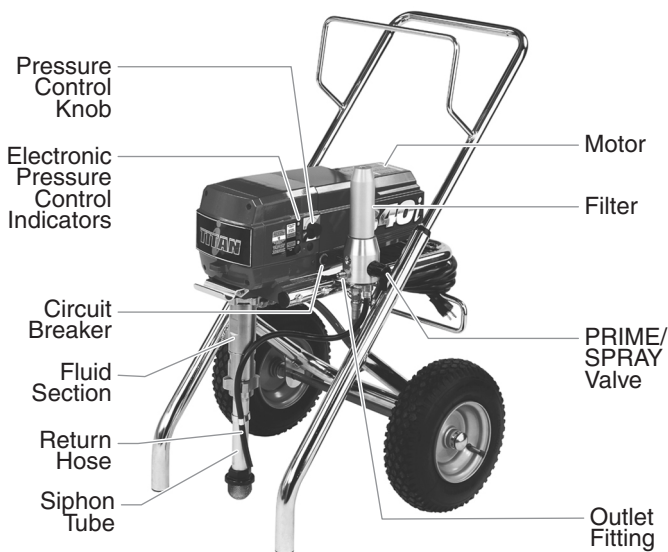

Operation



This equipment produces a fluid stream at extremely high pressure. Read and understand the warnings in the Safety Precautions section at the front of this manual before operating this equipment.

Setup

Perform the following procedure before plugging in the power cord of an electric unit.

1. Ensure that the siphon tube/siphon set and the return hose are attached and secure.
2. Using a wrench, attach a minimum of 50' of nylon airless spray hose to the unit. Tighten securely.
3. Attach an airless spray gun to the spray hose. Using two wrenches (one on the gun and one on the hose), tighten securely.

NOTE: Do not attach the tip to the spray gun yet. Remove the tip if it is already attached.



Make sure all airless hoses and spray guns are electrically grounded and rated for at least 3300 psi (220 bar) fluid pressure.

4. Make sure the pressure control knob is in its OFF position in the black zone.
5. Fill the wet cup with one tablespoon of piston seal lubricant (Piston Lube).

IMPORTANT: Never operate unit for more than ten seconds without fluid. Operating this unit without fluid will cause unnecessary wear to the packings.

6. Make sure the electrical service is 120V, 15 amp minimum.
7. Plug the power cord into a properly grounded outlet at least 25' from the spray area.

IMPORTANT: Always use a minimum 12 gauge, three-wire extension cord with a grounded plug. Never remove the third prong or use an adapter.

Preparing a New Sprayer

If this unit is new, it is shipped with test fluid in the fluid section to prevent corrosion during shipment and storage. This fluid must be thoroughly cleaned out of the system with mineral spirits before you begin spraying.

IMPORTANT: Always keep the trigger lock on the spray gun in the locked position while preparing the system.

1. Place the siphon tube into a container of mineral spirits.
2. Place the return hose into a metal waste container.
3. Move the PRIME/SPRAY valve down to the PRIME position.
4. Turn the unit on and set the pressure to minimum by turning the pressure control knob to the "Min PSI" setting in the yellow zone.

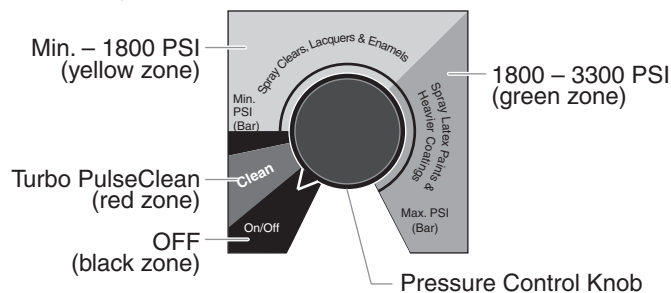

5. Allow the sprayer to run for 15–30 seconds to flush the test fluid out through the return hose and into the waste container.
6. Turn the unit off by moving the pressure control knob to the OFF position in the black zone.

Preparing to Paint

Before painting, it is important to make sure that the fluid in the system is compatible with the paint that is going to be used.

NOTE: Incompatible fluids and paint may cause the valves to become stuck closed, which would require disassembly and cleaning of the sprayer's fluid section.

IMPORTANT: Always keep the trigger lock on the spray gun in the locked position while preparing the system.

1. Place the siphon tube into a container of the appropriate solvent. Examples of the appropriate solvent are water for latex paint or mineral spirits for oil-based paints.
2. Place the return hose into a metal waste container.
3. Move the PRIME/SPRAY valve down to the PRIME position.
4. Turn the unit on and set the pressure to minimum by turning the pressure control knob to the "Min PSI" setting in the yellow zone.
5. Allow the sprayer to run for 15–30 seconds to flush the old solvent out through the return hose and into the metal waste container.
6. Turn the unit off by moving the pressure control knob to the OFF position in the black zone.

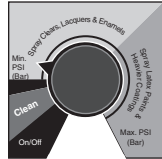

NOTE: Make sure that the spray gun does not have a tip or tip guard installed.

7. Move the PRIME/SPRAY valve up to the SPRAY position.
8. Turn the unit on and set the pressure to minimum by turning the pressure control knob to the "Min PSI" setting in the yellow zone.
9. Unlock the gun by turning the gun trigger lock to the unlocked position.



Ground the gun by holding it against the edge of the metal container while flushing. Failure to do so may lead to a static electric discharge, which may cause a fire.

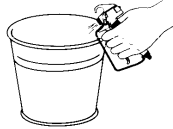

10. Trigger the gun into the metal waste container until the old solvent is gone and fresh solvent is coming out of the gun.
11. Lock the gun by turning the gun trigger lock to the locked position.
12. Set down the gun and increase the pressure by turning the pressure control knob slowly clockwise into the green zone.
13. Check the entire system for leaks. If in locked position. leaks occur, follow the "Pressure Relief Procedure" in this manual before tightening any fittings or hoses.
14. Follow the "Pressure Relief Procedure" in this manual before changing from solvent to paint.

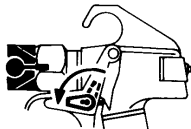

Trigger lock in locked position.



Be sure to follow the pressure relief procedure when shutting down the sprayer for any purpose, including servicing or adjusting any part of the spray system, changing or cleaning spray tips, or preparing for cleanup.

Painting

1. Place the siphon tube into a container of paint.
2. Place the return hose into a metal waste container.
3. Move the PRIME/SPRAY valve down to the PRIME position.

4. Turn the unit on and set the pressure to minimum by turning the pressure control knob to the "Min PSI" setting in the yellow zone.
5. Allow the sprayer to run until paint is coming through the return hose into the metal waste container.
6. Turn the unit off by moving the pressure control knob to the OFF position in the black zone.
7. Remove the return hose from the waste container and place it in its operating position above the container of paint.
8. Move the PRIME/SPRAY valve up to the SPRAY position.
9. Turn the unit on and set the pressure to minimum by turning the pressure control knob to the "Min PSI" setting in the yellow zone.
10. Unlock the gun by turning the gun trigger lock to the unlocked position.

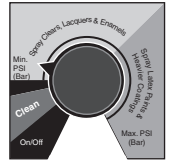

Ground the gun by holding it against the edge of the metal container while flushing. Failure to do so may lead to a static electric discharge, which may cause a fire.



11. Trigger the gun into the metal waste container until all air and solvent is flushed from the spray hose and paint is flowing freely from the gun.
12. Lock the gun by turning the gun trigger lock to the locked position.
13. Turn the unit off by moving the pressure control knob to the OFF position in the black zone.
14. Attach tip guard and tip to the gun as instructed by the tip guard or tip manuals. in locked position.

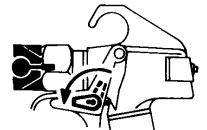

Trigger lock in locked position.



POSSIBLE INJECTION HAZARD. Do not spray without the tip guard in place. Never trigger the gun unless the tip is in either the spray or the unclog position. Always engage the gun trigger lock before removing, replacing or cleaning tip.

15. Turn the unit on and set the pressure to minimum by turning the pressure control knob to the "Min PSI" setting in the yellow zone.
16. Increase the pressure by turning the pressure control knob slowly clockwise toward the green zone and test the spray pattern on a piece of cardboard. Adjust the pressure control knob until the spray from the gun is completely atomized.

NOTE: Turning the pressure up higher than needed to atomize the paint will cause premature tip wear and additional overspray.

Electronic Pressure Control Indicators

The following is a description of the electronic pressure control indicators.

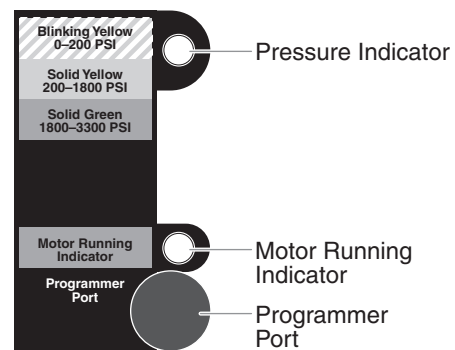

Pressure Indicator

The pressure indicator shows the current operating pressure of the sprayer. It has three different indications: blinking yellow, solid yellow, and solid green.

Blinking Yellow

When the pressure indicator is blinking yellow, the sprayer is operating between 0 and 200 PSI. A blinking yellow pressure indicator means:

- The sprayer is plugged in and turned "ON".
- The sprayer is at priming pressure (little or no pressure).
- It is safe to move the PRIME/SPRAY valve between positions.
- It is safe to change or replace the spray tip.

NOTE: If the pressure indicator begins blinking yellow when the pressure control knob is set at a higher pressure and the PRIME/SPRAY valve is in the SPRAY position, either the spray tip is worn or the sprayer is in need of service/repair.

Solid Yellow

When the pressure indicator is solid yellow, the sprayer is operating between 200 and 1800 PSI. A solid yellow pressure indicator means:

- The sprayer is at the proper pressure setting for spraying stain, lacquer, varnish, and multi-colors.
- If the pressure indicator goes to solid yellow when the pressure is set so that it starts at solid green, it indicates one of the following:
 - a. Tip Wear Indicator — when spraying with latex or at high pressure the solid yellow appears. This means the tip is worn and needs to be replaced.
 - b. Tip Too Large — when a tip that is too large for the sprayer is put in the gun, the pressure indicator will turn from solid green to solid yellow.
 - c. Fluid Section Wear — if a solid yellow pressure indicator appears when using a new tip and the pressure is set at maximum, service may be required (worn packings, worn piston, stuck valve, etc...).

Solid Green

When the pressure indicator is solid green, the sprayer is operating between 1800 and 3300 PSI. A solid green pressure indicator means:

- The sprayer is at the proper pressure setting for spraying oil-based and latex house paints.
- The sprayer is operating at peak performance at a high pressure setting.

Motor Running Indicator

The Motor Running indicator is on when the motor is commanded to run. This indicator is used by service centers to troubleshoot motor problems.

Pressure Relief Procedure



Be sure to follow the pressure relief procedure when shutting the unit down for any purpose, including servicing or adjusting any part of the spray system, changing or cleaning spray tips, or preparing for cleanup.

1. Lock the gun by turning the gun trigger lock to the locked position.
2. Turn the pressure control knob counterclockwise to its OFF position in the black zone.
3. Unlock the gun by turning the gun trigger lock to the unlocked position.



Trigger lock in locked position.

4. Hold the metal part of the gun firmly to the side of a metal container to ground the gun and avoid a build up of static electricity.
5. Trigger the gun to remove any pressure that may still be in the hose.
6. Lock the gun by turning the gun trigger lock to the locked position.
7. Move the PRIME/SPRAY valve down to the PRIME position.



Spraying



POSSIBLE INJECTION HAZARD. Do not spray without the tip guard in place. Never trigger the gun unless the tip is in either the spray or the unclog position. Always engage the gun trigger lock before removing, replacing, or cleaning tip.

Spraying Technique

The following techniques, if followed, will assure professional painting results.

Hold the gun perpendicular to the surface and always at equal distance from the surface. Depending on the type of material, surface, or desired spray pattern, the gun should be held at a distance of 12 to 14 inches (30 to 35 cm).

Move the gun either across or up and down the surface at a steady rate. Moving the gun at a consistent speed conserves material and provides even coverage. The correct spraying speed allows a full, wet coat of paint to be applied without runs or sags.

Holding the gun closer to the surface deposits more paint on the surface and produces a narrower spray pattern. Holding the gun farther from the surface produces a thinner coat and wider spray pattern. If runs, sags, or excessive paint occur, change to a spray tip with a smaller orifice. If there is an insufficient amount of paint on the surface or you desire to spray faster, a larger orifice tip should be selected.

Maintain uniform spray stroke action. Spray alternately from left to right and right to left. Begin movement of the gun before the trigger is pulled.

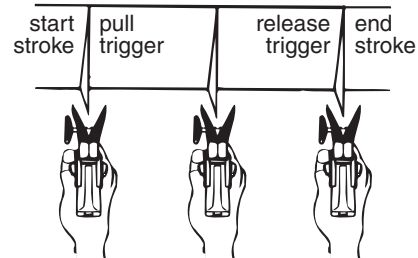

Avoid arcing or holding the gun at an angle. This will result in an uneven finish.

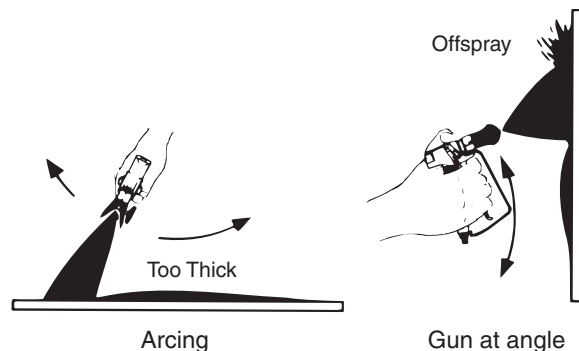

Proper lapping (overlap of spray pattern) is essential to an even finish. Lap each stroke. If you are spraying horizontally, aim at the bottom edge of the preceding stroke, so as to lap the previous pattern by 50%.

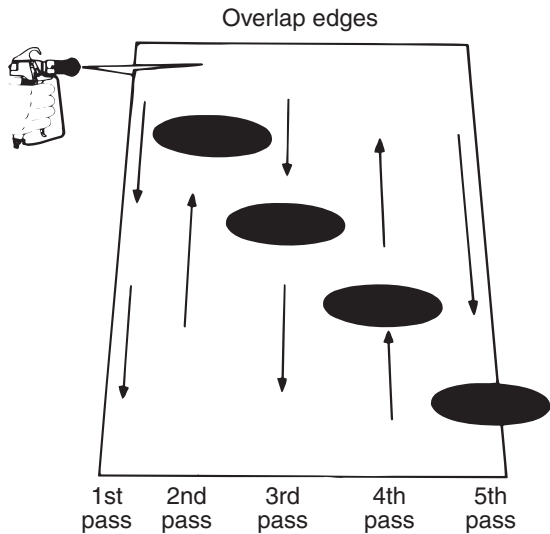

For corners and edges, split the center of the spray pattern on the corner or edge and spray vertically so that both adjoining sections receive approximately even amounts of paint.

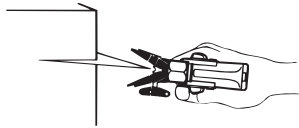

When spraying with a shield, hold it firmly against the surface. Angle the spray gun slightly away from the shield and toward the surface. This will prevent paint from being forced underneath.

Shrubs next to houses should be tied back and covered with a canvas cloth. The cloth should be removed as soon as possible. Titan gun extensions are extremely helpful in these situations.

Nearby objects such as automobiles, outdoor furniture, etc. should be moved or covered whenever in the vicinity of a spray job. Be careful of any other surrounding objects that could be damaged by overspray.

Practice

1. Be sure that the paint hose is free of kinks and clear of objects with sharp cutting edges.
2. Turn the pressure control knob counterclockwise to its lowest setting.
3. Turn the PRIME/SPRAY valve up to its SPRAY position.
4. Turn the pressure control knob clockwise to its highest setting. The paint hose should stiffen as paint begins to flow through it.
5. Unlock the gun trigger lock.
6. Trigger the spray gun to bleed air out of the hose.
7. When paint reaches the spray tip, spray a test area to check the spray pattern.
8. Use the lowest pressure setting necessary to get a good spray pattern. If the pressure is set too high, the spray pattern will be too light. If the pressure is set too low, tailing will appear or the paint will spatter out in gobs rather than in a fine spray.

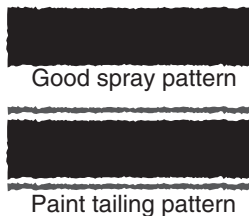

Cleanup



Special cleanup instructions for use with flammable solvents:

- Always flush spray gun preferably outside and at least one hose length from spray pump.
- If collecting flushed solvents in a one gallon metal container, place it into an empty five gallon container, then flush solvents.

- Area must be free of flammable vapors.
- Follow all cleanup instructions.

IMPORTANT: The sprayer, hose, and gun should be cleaned thoroughly after daily use. Failure to do so permits material to build up, seriously affecting the performance of the unit.



Always spray at minimum pressure with the gun nozzle tip removed when using mineral spirits or any other solvent to clean the sprayer, hose, or gun. Static electricity buildup may result in a fire or explosion in the presence of flammable vapors.

1. Follow the "Pressure Relief Procedure" found in the Operation section of this manual.
2. Remove the gun tip and tip guard and clean with a brush using the appropriate solvent.
3. Place the siphon tube into a container of the appropriate solvent. Examples of the appropriate solvent are water for latex paint or mineral spirits for oil-based paints.
4. Place the return hose into a metal waste container.
5. Move the PRIME/SPRAY valve down to its PRIME position.
6. Turn the unit on and set the pressure to Turbo PulseClean by turning the pressure control knob to its CLEAN position in the red zone.
7. Allow the solvent to circulate through the unit and flush the paint out of the return hose into the metal waste container.
8. Turn the unit off by moving the pressure control knob to the OFF position in the black zone.
9. Move the PRIME/SPRAY valve up to its SPRAY position.
10. Turn the unit on and set the pressure to Turbo PulseClean by turning the pressure control knob to its CLEAN position in the red zone.

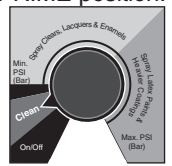

Ground the gun by holding it against the edge of the metal container while flushing. Failure to do so may lead to a static electric discharge, which may cause a fire.



11. Trigger the gun into the metal waste container until the paint is flushed out of the hose and solvent is coming out of the gun.
12. Continue to trigger the spray gun into the waste container until the solvent coming out of the gun is clean.

NOTE: For long-term or cold weather storage, pump mineral spirits through the entire system.

For short-term storage when using latex paint, pump water mixed with Titan Liquid Shield Plus through the entire system (see the Accessories section of this manual for part number).

13. Follow the "Pressure Relief Procedure" found in the Operation section of this manual.
14. Unplug the unit and store in a clean, dry area.

IMPORTANT: Do not store the unit under pressure.

Maintenance



Before proceeding, follow the Pressure Relief Procedure outlined previously in this manual. Additionally, follow all other warnings to reduce the risk of an injection injury, injury from moving parts or electric shock. Always unplug the sprayer before servicing!

General Repair and Service Notes

The following tools are needed when repairing this sprayer:

Phillips Screwdriver	3/8" Hex Wrench
Needle Nose Pliers	5/16" Hex Wrench
Adjustable Wrench	1/4" Hex Wrench
Rubber Mallet	3/16" Hex Wrench
Flat-blade Screwdriver	5/32" Hex Wrench

1. Before repairing any part of the sprayer, read the instructions carefully, including all warnings.

IMPORTANT: Never pull on a wire to disconnect it. Pulling on a wire could loosen the connector from the wire.

2. Test your repair before regular operation of the sprayer to be sure that the problem is corrected. If the sprayer does not operate properly, review the repair procedure to determine if everything was done correctly. Refer to the Troubleshooting Charts to help identify other possible problems.
3. Make certain that the service area is well ventilated in case solvents are used during cleaning. Always wear protective eyewear while servicing. Additional protective equipment may be required depending on the type of cleaning solvent. Always contact the supplier of solvents for recommendations.
4. If you have any further questions concerning your TITAN Airless Sprayer, call TITAN:

Customer Service (U.S.)	1-800-526-5362
Fax	1-800-528-4826
Customer Service (Canada)	1-800-565-8665
Fax	1-905-856-8496
Customer Service (International)	1-201-337-1240
Fax	1-201-405-7449

Replacing the PRIME/SPRAY Valve

Perform the following procedure using PRIME/SPRAY valve replacement kit P/N 800-915.

1. Push the groove pin out of the valve handle.
2. Remove the valve handle and the cam base.
3. Using a wrench, loosen and remove the valve housing assembly.
4. Make sure the gasket is in place and thread the new valve housing assembly into the filter block. Tighten securely with a wrench.
5. Place the cam base over the valve housing assembly. Lubricate the cam base with grease and line up the cam with the filter block using the dowel pin.
6. Line up the hole on the valve stem with the hole in the valve handle.
7. Insert the groove pin into the valve handle and through the valve stem to secure the valve handle in position.

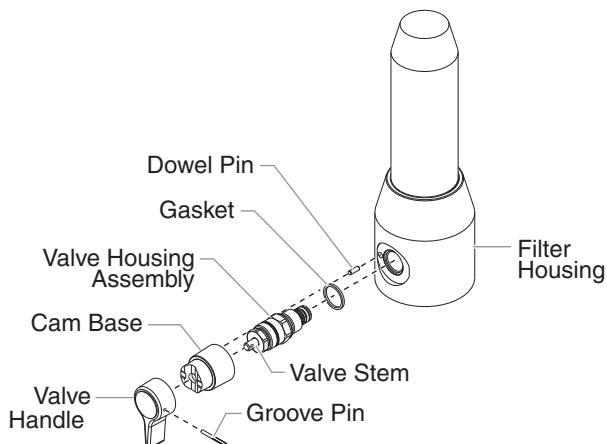

Replacing the Filters

Pump Filter

1. Loosen and remove the filter body by hand.
2. Slip the filter off of the core spring.
3. Inspect the filter. Based on inspection, clean or replace the filter.
4. Inspect the o-ring. Based on inspection, clean or replace the o-ring.
5. Slide the new or cleaned filter over the core spring with the filter spring adapter in place. Push the filter into the center of the filter housing.
6. Slide the filter body over the filter and thread it into the filter housing until secure.

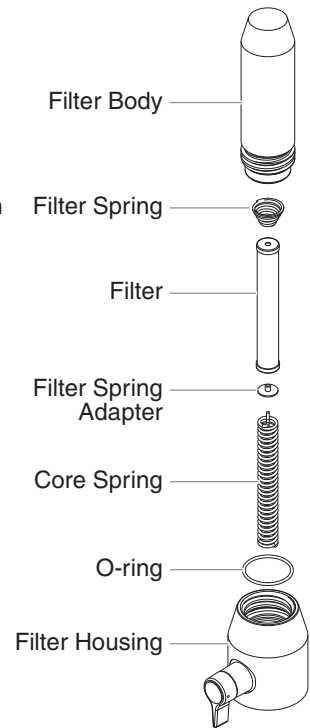

NOTE: The filter body should be hand-tightened, but make sure it is seated fully into the filter housing.

Gun Filter

1. Move the gun trigger lock to the unlocked position.
2. Loosen and remove the handle from the gun body.
3. Turning clockwise, unscrew the filter from the gun body.

NOTE: Left-handed threads require turning the filter clockwise to remove.

4. Turning counterclockwise, screw the new or cleaned filter into the gun body.
5. Make sure the handle seal is in position and thread the handle into the gun body until secure.
6. Move the gun trigger lock to the locked position.

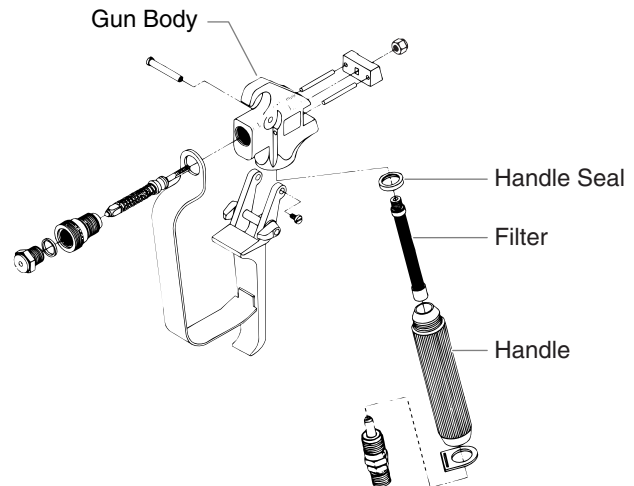

NOTE: For more detail, part number information, and assembly drawings at larger scale, please see the LX-80 Professional Airless Gun Owner's Manual (#313-012).

Replacing the Motor Assembly (with Electronic Control)

1. Unplug the unit.
2. Loosen and remove the four motor shroud screws. Remove the motor shroud.
3. Release the tie wrap on the top of the baffle assembly and slip the baffle assembly down off of the motor.
4. Loosen and remove the three electronic cover screws. Lift the electronic cover off of the electronic control assembly on the motor.
5. At the electronic control assembly:
 - a. Disconnect the white wire coming from the power cord and the white wire coming from the relay.
 - b. Disconnect the three wires coming from the potentiometer.
 - c. Disconnect the seven wires coming from the indicator lights assembly.
6. Loosen and remove the three motor mounting screws.
7. Pull the motor out of the gearbox housing.
8. With the motor removed, inspect the gears in the gearbox housing for damage or excessive wear. Replace the gears, if necessary.
9. Install the new motor into the gearbox housing. Make sure the housing gasket is positioned properly.
10. Secure the motor with the three motor mounting screws.
11. Reconnect the wires to the electronic control assembly (refer to the electrical schematic in the Parts List section of this manual).
12. Position the electronic cover over the electronic control assembly. Secure the electronic cover with the three electronic cover screws.
13. Slip the baffle assembly up and around the motor. Secure the baffle assembly with the tie wrap.
14. Slide the motor shroud over the motor. Make sure the shroud gasket is positioned properly.
15. Secure the motor shroud with the four motor shroud screws.

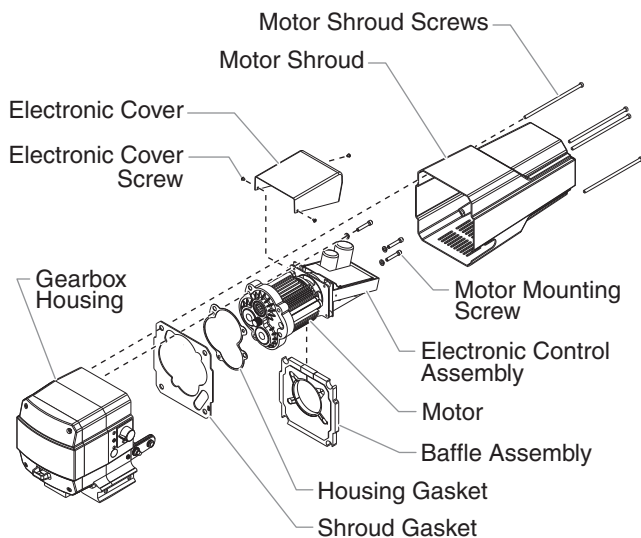

Replacing the Gears

1. Unplug the unit.
2. Loosen and remove the four motor shroud screws. Remove the motor shroud.
3. Release the tie wrap on the top of the baffle assembly and slip the baffle assembly down off of the motor.
4. Loosen and remove the three electronic cover screws. Lift the electronic cover off of the electronic control assembly on the motor.
5. At the electronic control assembly:
 - a. Disconnect the white wire coming from the power cord and the white wire coming from the relay.
 - b. Disconnect the three wires coming from the potentiometer.
 - c. Disconnect the seven wires coming from the indicator lights assembly.
6. Loosen and remove the three motor mounting screws.
7. Pull the motor out of the gearbox housing.
8. Inspect the armature gear on the end of the motor for damage or excessive wear. If this gear is completely worn out, replace the front end bell assembly.
9. Remove and inspect the 1st stage gear and 2nd stage gear assemblies for damage or excessive wear. Replace, if necessary.
10. Remove and inspect the front gear box assembly for damage or excessive wear. If damaged or worn, replace the front gear box assembly.

NOTE: Clean and refill the gear box cavity up to the rear face of each gear with Lubriplate (P/N 314-171).

11. Install the motor into the gearbox housing. Make sure the housing gasket is positioned properly.
12. Secure the motor with the three motor mounting screws.
13. Reconnect the wires to the electronic control assembly (refer to the electrical schematic in the Parts List section of this manual).
14. Position the electronic cover over the electronic control assembly. Secure the electronic cover with the three electronic cover screws.
15. Slip the baffle assembly up and around the motor. Secure the baffle assembly with the tie wrap.
16. Slide the motor shroud over the motor. Make sure the shroud gasket is positioned properly.
17. Secure the motor shroud with the four motor shroud screws.

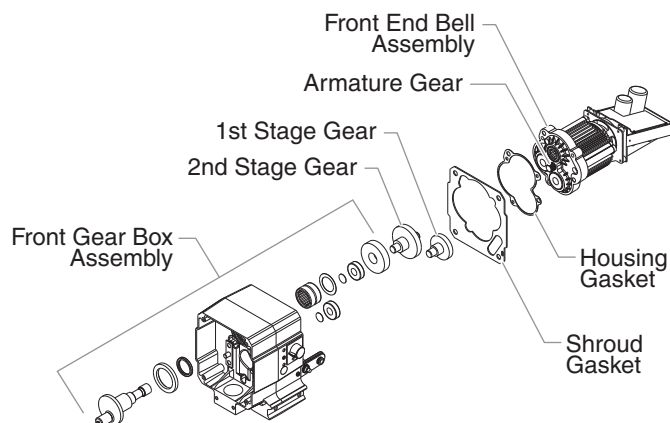

Replacing the Transducer

1. Unplug the unit.
2. Loosen and remove the four motor shroud screws. Remove the motor shroud.
3. At the electronic control assembly, disconnect the black wire coming from the transducer.
4. Pull the grommet out of the mounting plate and slide it up the shaft of the transducer until it is clear of the mounting plate.
5. Using a wrench, loosen and remove the transducer from the filter housing. Carefully thread the transducer wire out through the mounting plate.
6. Slide the grommet off of the old transducer and onto the new transducer.
7. Thread the new transducer wire through the mounting plate and up to the electronic control assembly.
8. Thread the new transducer into the filter housing and tighten securely with a wrench.

NOTE: Make sure the o-ring on the transducer is in place before threading the transducer into the filter housing.

9. Push the grommet into the mounting plate.
10. Connect the transducer wire to the electronic control assembly (refer to the electrical schematic in the Parts List section of this manual).
11. Slide the motor shroud over the motor. Make sure the shroud gasket is positioned properly.
12. Secure the motor shroud with the four motor shroud screws.

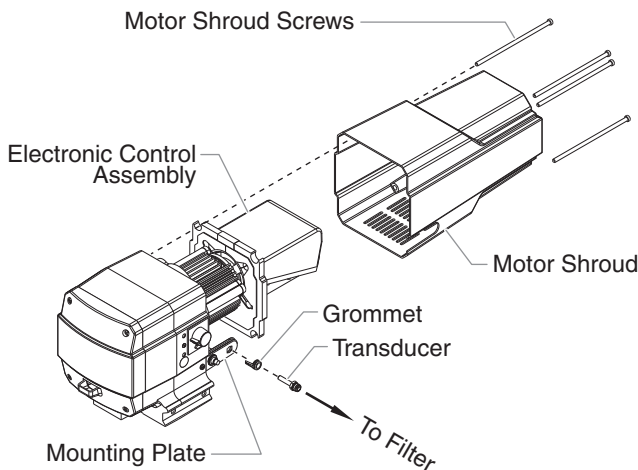

Servicing the Fluid Section

Use the following procedures to service the valves and repack the fluid section. Perform the following steps before performing any maintenance on the fluid section.

1. Loosen and remove the four front cover screws. Remove the front cover.
2. Position the crankshaft/slider assembly at the bottom, dead-center of its stroke so that the connecting pin and retaining ring are visible below the slider assembly. This is done by turning the sprayer on and off in short bursts until the connecting pin is visible below the slider housing.
3. Turn off and unplug the unit.



Before proceeding, follow the Pressure Relief Procedure outlined previously in this manual. Additionally, follow all other warnings to reduce the risk of an injection injury, injury from moving parts or electric shock. Always unplug the sprayer before servicing!

4. Remove the return hose from the clamp on the siphon tube.
5. Unscrew the siphon tube/siphon set from the foot valve.
6. Loosen and remove the high-pressure hose from the nipple on the back of the upper housing of the fluid section.

Servicing the Valves

The design of the fluid section allows access to the foot valve and seat as well as the outlet valve and seat without completely disassembling the fluid section. It is possible that the valves may not seat properly because of debris stuck in the foot valve seat or outlet valve seat. Use the following instructions to clean the valves and reverse or replace the seats.

1. Loosen and remove the foot valve housing from the lower housing.
2. Clean out any debris in the foot valve housing and examine the housing and the foot valve seat. If the seat is damaged, reverse or replace the seat.
3. Using two wrenches, hold the upper housing at the wrench flats with one wrench and loosen the lower housing with the other. Remove the lower housing.

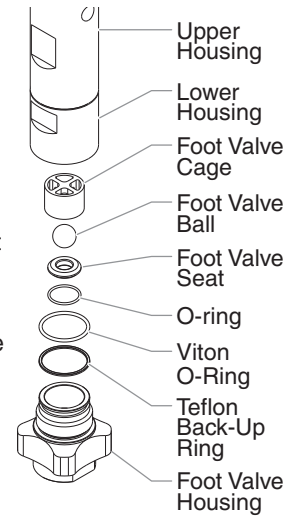

4. Using a 3/4" wrench, loosen and remove the outlet valve retainer from the piston rod.

NOTE: Always service the outlet valve with the piston rod attached to the pump. This will prevent the piston rod from rotating during disassembly of the outlet valve.

5. Clean out any debris and examine the retainer and outlet valve seat. If the seat is damaged, reverse or replace the seat.
6. Remove, clean, and inspect the outlet valve cage and outlet valve ball. Replace if they are worn or damaged.
7. Reassemble the valves by reversing the steps above.

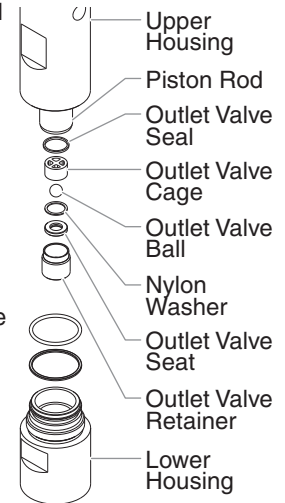

NOTE: During reassembly, make sure the Viton o-rings and the Teflon back-up rings between the upper housing and lower housing as well as between the lower housing and the foot valve housing are lubricated with grease and in position.

Repacking the Fluid Section

NOTE: The factory-installed packings are black in color. The replacement packings in the packing replacement kit are white.

1. Remove the foot valve assembly and the lower housing using the steps in the "Servicing the Valves" procedure above.

NOTE: The outlet valve does not need to be disassembled from the piston rod for this procedure.

2. Slide the retaining ring up on the slider assembly to expose the connecting pin.
3. Push the connecting pin forward through the slider assembly and piston. The connecting pin will fall into a recessed area of the gear box housing where it can be retrieved.
4. Tap the knock-off nut with a soft hammer so that it turns counterclockwise and loosens.
5. Turn the fluid section counterclockwise to remove it from the gear box housing.
6. Place the upper housing upright in a vise by clamping on the wrench flats.

NOTE: Do not over-tighten the vise. Damage to the upper housing may occur.

7. Using a wrench, remove the upper seal retainer.
8. Slide the piston rod out through the bottom of the upper housing.
9. Inspect the piston rod for wear and replace if necessary.
10. Remove the upper and lower packings from the upper housing.

NOTE: Be careful not to scratch, score, or otherwise damage the upper housing during removal of the packings.

11. Clean the upper housing. Inspect the upper housing for damage and replace if necessary.
12. Locate the new upper and lower packings and pack the areas between the packing lips with grease. Lubricate the o-rings on the exterior of the packings with grease.

13. Insert the upper packing into the top of the upper housing with the raised lip on the packing facing down.
14. Insert the spacer on top of the upper packing.
15. Thread the upper seal retainer into the upper housing and torque to 25-30 ft. lbs.

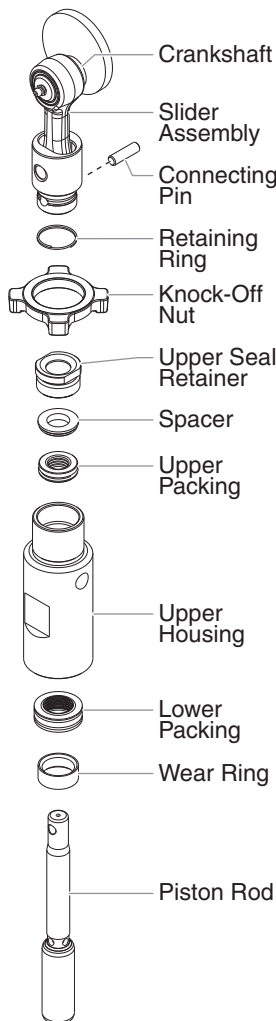

Install upper packing with raised lip facing down.



Raised Lip

16. Pre-form the lower packing using the lower packing sizing tool (included in the repacking kit).
17. Insert the lower packing partially into the bottom of the upper housing so that the side that has the o-ring closest to the face of the packing faces up.
18. Push the lower packing into position using the lower packing insertion tool (see Fluid Section Assembly parts list for lower packing insertion tool P/N).
19. Place the piston insertion tool (included in the repacking kit) over the top of the piston rod.
20. Insert the piston rod into the bottom of the upper housing, through the lower packing, through the upper packing, and out through the upper seal retainer.

Install lower packing with the side that has the o-ring closest to the face of the packing facing up.

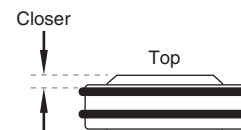

NOTE: When repacking the fluid section, make sure the raised lip on the bottom of the lower packing is fully outside the packing around the piston rod after insertion of the piston rod.

21. Remove the piston insertion tool from the top of the piston rod.
22. Turn the knock-off nut counterclockwise until it is flush against the upper housing.
23. Lubricate the threads on the upper housing with anti-seize compound. Remove the upper housing from the vise.
24. Thread the upper housing into the gear box housing, turning clockwise. When the connecting pin hole on the piston rod lines up with the hole in the slider assembly, insert the connecting pin.
25. Slide the retaining ring down over the connecting pin.
26. Continue to turn the upper housing clockwise until the knock-off nut is flush against the gear box housing.

NOTE: If the nipple on the upper housing does not face the back of the unit, turn the upper housing counterclockwise until the nipple faces the back of the unit. Do not turn the upper housing more than one full turn.

27. Once the nipple is positioned, turn the knock-off nut clockwise until it contacts the gear box housing.
28. Tap the knock-off nut with a soft hammer to tighten it against the gear box housing.
29. Making sure that the Viton o-ring and Teflon back-up ring are lubricated and in place, thread the lower housing into the upper housing. Using two wrenches, hold the upper housing at the wrench flats with one wrench and tighten the lower housing with the other.
30. Attach the high-pressure hose to the nipple on the back of the housing and tighten with a wrench. Do not kink the hose.

NOTE: For low rider units, make sure the hose does not touch the cart frame. If it does, reposition the nipple by turning the upper housing until the hose is clear of the frame and the nipple is within 45° of the back of the unit.

31. Making sure that the Viton o-ring and Teflon back-up ring are lubricated and in place, reassemble the foot valve assembly and thread it into the lower housing. Tighten securely.
32. Thread the siphon tube/siphon set into the foot valve and tighten securely. Make sure to wrap the threads on the down tube/siphon hose adapter with Teflon tape before assembly.
33. Replace the return hose into the clamp on the siphon tube.
34. Place the front cover on the gearbox housing and secure in position using the four front cover screws.
35. Turn on the sprayer by following the procedure in the "Operation" section of this manual and check for leaks.

NOTE: Repacking kit P/N 800-273 is available. For best results use all parts supplied in this kit.

Troubleshooting

Airless Sprayer

Problem

Electric motor won't run

Cause

1. Unit unplugged or circuit fuse blown
2. Pressure setting too low
3. Electric motor burned out
4. Switch defective
5. Circuit breaker on sprayer tripped

Solution

1. Check
2. Increase
3. Replace
4. Replace
5. Reset the breaker

Sprayer won't prime

1. Air in line
2. Insufficient pressure

1. Check siphon tube o-ring and/or let paint circulate in prime position
2. Increase pressure

Insufficient material flow

1. No paint
2. Siphon strainer clogged
3. Sprayer/gun filter clogged
4. Sprayer will not prime, material too heavy

1. Check supply
2. Clean
3. Clean & replace
4. Thin material

Sprayer will not maintain pressure

1. Air leak in system
2. Air leak in siphon tube
3. Inlet valve not seating
4. Worn packings
5. Dirty or worn ball valves
6. Worn valve seats
7. Worn prime valve

1. Tighten connections
2. Tighten, check for leaks
3. Service or clean
4. Replace
5. Clean or replace
6. Reverse
7. Replace

Not enough pressure

1. Pressure setting too low
2. Plugged filters
3. Spray tip too big or worn

1. Increase
2. Clean or replace
3. Change or replace

Excessive surge at spray gun

1. Wrong type of hose
2. Spray tip too big or worn
3. Excessive pressure

1. Replace with a minimum 50' grounded nylon braid high pressure hose
2. Change or replace
3. Decrease pressure and engine speed

Paint leaks into oil cup

1. Worn out packings

1. Replace

Airless Gun

Problem

Spitting gun

Cause

1. Air in system
2. Dirty gun
3. Needle assembly out of adjustment
4. Broken or chipped seat

Solution

1. Inspect connections for air leaks
2. Disassemble and clean
3. Inspect and adjust
4. Inspect and replace

Gun will not shut off

1. Worn or broken needle & seat
2. Needle assembly out of adjustment
3. Dirty gun

1. Replace
2. Adjust
3. Clean

Gun does not spray

1. No paint
2. Plugged filter or tip
3. Broken needle in gun

1. Check fluid supply
2. Clean
3. Replace

Troubleshooting

Spray Patterns

Problem

Tails

Cause

1. Inadequate fluid delivery
2. Fluid not atomizing
3. Insufficient velocity
4. Material too cohesive
5. Tip worn past sprayer capacity

Solution

1. Increase pressure
2. Change to smaller tip
3. Clean gun and pump filters
4. Reduce viscosity
5. Replace

Heavy centered pattern

1. Worn tip
2. Tip may be chipped

1. Replace
2. Replace

Distorted pattern

1. Plugged, worn or chipped tip

1. Clean or replace

Pattern expanding and contracting (Surge)

1. Leak in suction tube
2. Not enough hose
3. Tip too large or worn

1. Tighten
2. Use a minimum of 50' (15m) of 1/4" high pressure hose
3. Replace with a new or smaller tip

Patents

These products are covered by one or more of the following U.S. patents:

4,500,119 4,768,929



Importantes consignes de sécurité • Lire toutes ces consignes avant d'utiliser l'appareil. Garder ces consignes.



Indique une situation à risque, laquelle, si elle n'est pas évitée, peut entraîner des blessures graves, voire la mort.



Pour réduire les risques d'incendie ou d'explosion, de choc électrique et de blessure, vous devez lire et comprendre les directives figurant dans ce manuel. Familiarisez-vous avec les commandes et l'utilisation adéquate de l'équipement.

DANGER : INJECTION CUTANÉE

Le jet de haute pression produit par cet appareil peut transpercer la peau et les tissus sous-jacents, causant des blessures graves pouvant entraîner l'amputation.



NE PAS TRAITER CE TYPE DE BLESSURE COMME UNE SIMPLE COUPURE! Une amputation peut en résulter. ON DOIT CONSULTER UN MÉDECIN SUR-LE-CHAMP.

La pression maximale de ce pulvérisateur est d'environ 3 300 PSI / 228 BAR.

MESURES PRÉVENTIVES :

- Ne pas pointer le pistolet vers une partie du corps.
- Ne pas pointer le pistolet vers une personne ou un animal; ne pas pulvériser non plus de produit dessus.
- NE JAMAIS mettre une partie du corps devant le jet de produit. NE JAMAIS toucher les fuites du flexible de pulvérisation.
- NE JAMAIS mettre la main, même gantée, devant le pistolet (les gants n'offrent aucune protection contre les blessures par injection).
- TOUJOURS verrouiller la détente, arrêter la pompe et relâcher toute la pression avant d'effectuer la maintenance de l'appareil ou de le laisser sans surveillance, d'en nettoyer le protège-embout ou l'embout, ou de remplacer ce dernier. La pression ne sera pas relâchée par le simple arrêt du moteur; pour ce faire, on doit se servir du bouton PRIME/SPRAY (se reporter à la section COMMENT LIBÉRER LA PRESSION, du présent manuel).
- TOUJOURS s'assurer que le protège-embout est en place avant de pulvériser. Il est cependant à noter que, s'il assure une certaine protection, ce dispositif joue surtout un rôle préventif.
- TOUJOURS retirer l'embout avant de vidanger ou de nettoyer l'appareil.
- TOUJOURS inspecter le flexible avant de commencer; celui-ci peut présenter des fuites attribuables à l'usure, à une flexion excessive ou à un traitement abusif, lesquelles fuites présentent des risques d'injection cutanée. Ne pas utiliser le flexible pour soulever ou tirer l'équipement.
- NE JAMAIS utiliser de pistolet sans verrou de détente et protège-doigts.
- Tous les accessoires (pistolets, embouts, rallonges, flexibles etc.) doivent pouvoir subir une pression nominale de 3 300 PSI / 228 BAR ou plus.
- Ne laissez pas l'appareil sous tension ou sous pression quand vous vous en éloignez. Quand vous n'utilisez pas l'appareil, éteignez-le et libérez la pression conformément aux instructions COMMENT LIBÉRER LA PRESSION, du présent manuel.
- Vérifiez que toutes les connexions sont bien serrées avant d'utiliser l'appareil. Toute pièce qui n'est pas fixée solidement risque d'être projetée violemment ou d'entraîner la fuite d'un jet de liquide à une pression extrêmement élevée, ce qui pourrait causer des blessures graves.
- Verrouillez toujours la détente quand vous ne pulvériser pas. Vérifiez que le verrou de la détente fonctionne correctement.

REMARQUE À L'INTENTION DES MÉDECINS :

Les injections cutanées sont des lésions traumatiques; il importe donc de les traiter sans délai. On NE DOIT PAS retarder ce traitement sous prétexte de vérifier la toxicité du produit en cause, celle-ci n'étant conséquente que dans le cas d'injection directe de certains produits dans le système sanguin. Il pourrait s'avérer nécessaire de consulter un plasticien ou un spécialiste en chirurgie reconstructive de la main.

DANGER : ÉMANATIONS DANGEREUSES

Certains produits (peintures, solvants, insecticides ou autres) peuvent être nocifs s'ils sont inhalés ou entrent en contact avec l'organisme. Les émanations de ces produits peuvent provoquer de graves nausées, évanouissements ou empoisonnements.



MESURES PRÉVENTIVES :

- Se servir d'un masque ou d'un respirateur s'il y a risque d'inhalation (lire toutes les directives concernant ces dispositifs afin de s'assurer qu'ils offrent la protection requise).
- Porter des lunettes de protection.
- Porter les vêtements de protection prescrits par le fabricant du produit utilisé.



DANGER : EXPLOSION OU INCENDIE

Les émanations de certains produits peuvent exploser ou s'enflammer, et risquent d'entraîner des dommages matériels ou de graves blessures.



MESURES PRÉVENTIVES :

- S'assurer que l'aire de travail est dotée de moyens d'évacuation d'air vicié et d'introduction d'air frais pour éviter l'accumulation de vapeurs inflammables. Les vapeurs dégagées par la peinture ou les solvants peuvent provoquer une explosion ou s'enflammer.
- Ne pas pulvériser de produit dans un endroit clos.
- Ne pas travailler près de sources d'ignition (décharges électrostatiques ou étincelles provoquées par le branchement/ débranchement d'appareils ou la commutation d'interrupteurs, d'appareils électriques, flammes nues, veilleuses, objets chauds, etc.). La peinture ou le solvant s'écoulant dans l'équipement peut générer de l'électricité statique.
- Ne pas fumer dans l'aire de travail.
- L'aire de travail doit être munie d'un extincteur en bon état de marche.
- Prévoir un espace d'au moins 7.62 mètres entre la pompe et l'objet à pulvériser s'ils sont dans la même pièce bien ventilée (rallonger le flexible au besoin). Les vapeurs inflammables étant souvent plus lourdes que l'air, l'espace au-dessus du plancher doit être particulièrement bien aéré. La pompe contient des pièces qui produisent des arcs et émettent des étincelles pouvant enflammer les vapeurs.
- Les appareils et objets à l'intérieur ou à proximité de l'aire de travail doivent être adéquatement mis à la terre pour éviter les décharges électrostatiques.
- Veillez à ce que la zone soit propre et exempte de contenants de peinture ou de solvant, chiffons ou autres matériaux inflammables.
- Les flexibles dont on se sert doivent être conçus pour subir les pressions élevées et faits de matériaux conducteurs ou mis à la terre adéquatement; le pistolet sera mis à la terre par le biais de ses raccords aux flexibles.
- Pour les appareils électriques — Le cordon d'alimentation doit être branché à un circuit trifilaire.
- L'appareil doit toujours être vidangé à basse pression, embout retiré, dans un contenant métallique distinct. Tenir le pistolet contre la paroi du contenant de manière à mettre ce dernier à la terre et à prévenir les décharges électrostatiques.
- Toujours respecter les mises en garde et les directives du fabricant des produits et solvants utilisés. On doit connaître les produits contenus dans les peintures et solvants qu'on pulvérise. Lire les fiches techniques santé-sécurité (FTSS) et les étiquettes des contenants fournies avec les peintures et solvants. Suivre les consignes de sécurité du fabricant de peinture et de solvant.
- S'entourer de toutes les précautions possibles lorsqu'on utilise des produits ayant un point d'éclair inférieur à 21°C (70°F). Le point d'éclair est la température à laquelle le liquide peut créer suffisamment de vapeurs et s'enflammer.
- Le plastique est générateur de décharges électrostatiques; ne jamais en suspendre pour fermer une aire de travail ou en utiliser en guise de toile de protection lorsqu'on pulvérise un produit inflammable.
- Se servir de la pression la plus basse possible pour vidanger l'appareil.
- Ne pas pulvériser de produit sur la pompe.





Importantes consignes de sécurité • Lire toutes ces consignes avant d'utiliser l'appareil. Garder ces consignes.

DANGER : EXPLOSION CAUSÉE PAR DES PRODUITS INCOMPATIBLES



Ce type d'explosion peut entraîner des dommages matériels ou des blessures graves.

MESURES PRÉVENTIVES :

- Ne pas utiliser de produits contenant du chlore ou du javellisant.
- Ne pas utiliser de solvants à base de halons comme l'eau de javel, les agents antimoississure, le chlorure de méthylène et le trichloroéthane-1-1-1, lesquels ne sont pas compatibles avec l'aluminium.
- Communiquer avec le fournisseur du produit concerné pour en connaître la compatibilité avec l'aluminium.

DANGER : GÉNÉRALITÉS

D'autres dangers peuvent entraîner des dommages matériels ou des blessures graves.

- Lire toutes les directives et consignes de sécurité avant d'utiliser l'appareil.
- Observer tous les codes locaux, provinciaux, d'état et nationaux régissant la ventilation, la prévention des incendies et le fonctionnement de l'appareil.
- Aux États-Unis, le gouvernement a adopté des normes de sécurité en vertu de l'Occupational Safety and Health Act (OSHA). Le cas échéant, on doit les consulter, notamment les parties 1910 des normes générales et 1926 des normes de construction.
- N'utiliser que les pièces autorisées par le fabricant; les utilisateurs qui choisiront d'utiliser des composants dont les caractéristiques techniques et les exigences en matière de sécurité sont inférieures devront en assumer tous les risques et responsabilités.
- Tous les raccords, les tuyaux et les bouchons de remplissage doivent être fixés solidement en place avant d'utiliser la pompe de pulvérisation. Toute pièce qui n'est pas fixée solidement risque d'être projetée violemment ou d'entraîner la fuite d'un jet de liquide à une pression extrêmement élevée, ce qui pourrait causer des blessures graves.
- Avant chaque utilisation, examiner tous les flexibles afin de confirmer l'absence de coupures, de fuites, d'abrasions ou de renflements. Vérifier également l'intégrité des raccords. Remplacer sans délai les pièces qui semblent présenter des défauts. Ne jamais tenter de réparer un flexible; remplacer ceux qui font défaut par des modèles haute pression, avec mise à la terre.
- Ne faites pas de noeud avec le tuyau et ne le tordez pas trop. Le tuyau à vide peut présenter des fuites suite à l'usure, les noeuds ou les mauvais traitements. Une fuite risque d'injecter du produit dans la peau.
- N'exposez pas le tuyau à des températures ou des pressions supérieures à celles spécifiées par le fabricant.
- Ne pas pulvériser à l'extérieur par grands vents.
- Porter des vêtements aptes à protéger la peau et les cheveux du produit utilisé.
- Ne pas utiliser le pistolet ou ne pas pulvériser de produits en présence d'enfants à proximité. Éloigner les enfants de l'équipement en tout temps.
- Ne pas s'étirer ni ne travailler sur un support instable. Toujours garder les deux pieds au sol pour rester en équilibre.
- Se servir de la pression la plus basse possible pour vidanger l'appareil.
- Rester vigilant et faire attention à ce que l'on fait.
- Ne pas se servir de l'équipement en cas de fatigue ou si vos aptitudes sont affaiblies par la consommation de drogues ou de boissons alcoolisées.
- Pour les appareils électriques — Débranchez toujours le cordon électrique de la prise avant de travailler sur l'équipement.
- N'utilisez pas le tuyau pour tirer ou soulever l'équipement.
- Ne pas soulever par la poignée de chariot en chargeant ou en déchargeant.

Instructions de mise à la terre

Cet appareil doit être mis à la terre. La mise à la terre réduit les risques d'électrocution lors d'un court-circuit en permettant au courant de s'écouler par le fil de mise à la terre. Cet appareil est muni d'un cordon électrique avec fil de mise à la terre ainsi que d'une fiche de terre. La fiche doit être branchée sur une prise installée correctement et mise à la terre conformément à la réglementation et aux codes en vigueur.



Le fait de ne pas brancher correctement la fiche trifilaire de l'appareil peut entraîner des risques de choc électrique.



Si on doit réparer ou remplacer le cordon ou la fiche, ne pas raccorder le fil de terre à la borne des broches plates (lames) de cette dernière. Ce fil, normalement vert (avec ou sans rayures jaunes), doit être relié à la broche de terre.

Consulter un technicien ou un électricien qualifié à défaut de comprendre l'ensemble des présentes directives ou en cas d'incertitude quant à la mise à terre de l'appareil. Ne pas modifier la fiche de l'appareil; si elle ne s'adapte pas dans la prise voulue, faire remplacer cette dernière par un électricien qualifié.

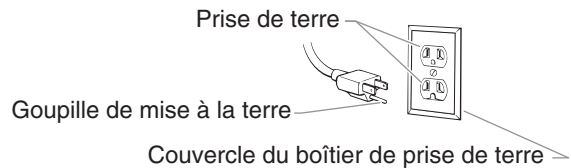

IMPORTANT : Utiliser uniquement une rallonge à trois fils munie d'une fiche de terre dans une prise secteur mise à la terre correspondant au type de fiche de l'appareil. S'assurer que votre rallonge est en bon état. Lorsque vous utilisez une rallonge, assurez-vous qu'elle soit d'un calibre suffisant pour supporter l'intensité du courant requise par l'appareil. Une rallonge trop mince entraîne une chute de tension, une diminution de l'intensité et une surchauffe. Une rallonge de calibre 12 est recommandée. Si vous devez utiliser une rallonge à l'extérieur, celle-ci doit comprendre la marque W-A après la désignation indiquant le type de cordon. Par exemple, la désignation SJTW-A indique que le cordon est conçu pour être utilisé à l'extérieur.



Información de seguridad importante • Lea toda la información de seguridad antes de operar el equipo. Guarde estas instrucciones.



Indica una situación peligrosa que, de no evitarse, puede causar la muerte o lesiones graves.



Para reducir los riesgos de incendios, explosiones, descargas eléctricas o lesiones a las personas, lea y entienda todas las instrucciones incluidas en este manual. Familiarícese con los controles y el uso adecuado del equipo.

PELIGRO: LESIÓN POR INYECCIÓN

El flujo de pintura a alta presión que produce este equipo puede perforar la piel y los tejidos subyacentes, ocasionando lesiones graves y posible amputación. CONSULTE A UN MÉDICO INMEDIATAMENTE.



¡NO TRATE LA LESIÓN POR INYECCIÓN COMO UNA CORTADURA SIMPLE! La inyección puede ocasionar amputación. Consulte a un médico inmediatamente.

La gama operativa máxima de la pistola es de 3300 PSI / 228 BAR de presión del líquido.

PREVENCIÓN:

- NUNCA apunte la pistola a ninguna parte del cuerpo.
- No apunte con la pistola ni rocíe a cualquier persona o animal.
- NUNCA deje que ninguna parte del cuerpo toque el flujo de líquido. NO deje que el cuerpo toque una fuga de la manguera de líquido.
- NUNCA ponga la mano frente a la pistola. Los guantes no protegen contra una lesión por inyección.
- SIEMPRE ponga el seguro del gatillo, apague la bomba y libere toda la presión antes de dar servicio, limpiar la boquilla o protección, cambiar la boquilla o dejar la pistola sin supervisión. No se libera la presión al apagar el motor. Debe girarse la perilla PRIME/ SPRAY (CEBAR/ROCIAR) a PRIME (CEBAR) para aliviar la presión. Consulte el PROCEDIMIENTO PARA ALIVIAR LA PRESIÓN descrito en este manual.
- SIEMPRE mantenga la protección de la boquilla en su sitio al rociar. La protección de la boquilla sirve principalmente de dispositivo de advertencia.
- SIEMPRE retire la boquilla rociadora antes de enjuagar o limpiar el sistema.
- La manguera de pintura puede presentar fugas por desgaste, dobleces y maltrato. La fuga puede inyectar material traspasando la piel. Inspeccione la manguera antes de cada uso. No use mangueras para levantar o tirar del equipo.
- NUNCA use una pistola rociadora sin contar con el seguro y la protección del gatillo.
- Todos los accesorios deben tener capacidades nominales de 3300 PSI / 228 BAR como mínimo. Esto incluye las boquillas rociadoras, pistolas, extensiones y manguera.
- No deje el aparato con corriente ni con presión cuando nadie esté pendiente de ella. Cuando no utilice el aparato, apáguelo y libere la presión siguiendo las instrucciones del PROCEDIMIENTO PARA ALIVIAR LA PRESIÓN descrito en este manual.
- Antes de utilizar el aparato, verifique que todas las conexiones son seguras. Las partes no aseguradas pueden ser expulsadas con gran fuerza o filtrar fluido a alta presión y provocar lesiones severas.
- Ponga siempre el seguro del gatillo cuando no esté pulverizando. Verifique que el seguro del gatillo funciona correctamente.

NOTA PARA EL MÉDICO: La inyección a través de la piel es una lesión traumática. Es importante tratar la lesión tan pronto sea posible. NO retrase el tratamiento para investigar la toxicidad. La toxicidad es un factor a considerar con ciertos revestimientos inyectados directamente en la corriente sanguínea. Puede ser aconsejable consultar con un cirujano plástico o un cirujano especialista en reconstrucción de las manos.

PELIGRO: VAPORES PELIGROSOS

Las pinturas, solventes, insecticidas y demás materiales pueden ser nocivos si se inhalan o toman contacto con el cuerpo. Los vapores pueden causar náuseas graves, desmayos o envenamamiento.



PREVENCIÓN:

- Use un respirador o mascarilla si pueden inhalarse los vapores. Lea todas las instrucciones suministradas con la mascarilla para revisar que brinde la protección necesaria.
- Use lentes protectores.
- Use ropa protectora según lo indique el fabricante del revestimiento.



PELIGRO: EXPLOSIÓN O INCENDIO

Los vapores de solventes y pinturas pueden explotar o inflamarse. Pueden producirse daños materiales, lesiones graves o ambos.



PREVENCIÓN:

- Cuente con escape y entrada de aire fresco para mantener el aire dentro de la zona de aplicación sin acumulaciones de vapores inflamables. Los gases producidos por solventes o pinturas pueden causar explosiones o incendios.
- No rocíe en lugares cerrados.
- Evite todas las fuentes de ignición como las chispas de electricidad estática, las llamas expuestas, appliances eléctricas, las luces piloto y los objetos calientes. La conexión o desconexión de cables eléctricos o interruptores de luz operativos puede producir chispas. Si la pintura o el solvente fluyen por el equipo se puede generar electricidad estática.
- No fume en el área de aplicación.
- Debe haber un extintor de incendios en buen estado.
- Coloque la bomba de pintura a un mínimo de 7.62 meters (25 pies) del objeto a pintar dentro de un área bien ventilada (añada más manguera si es necesario). Los vapores inflamables son generalmente más pesados que el aire. El área debe estar sumamente bien ventilada.
- El equipo y los objetos dentro y alrededor del área a pintar deben estar debidamente conectados a tierra para evitar las chispas de estática.
- Mantenga el área limpia y libre de contenedores de pintura o solvente, trapos y otros materiales inflamables.
- Use solamente una manguera conductora o conectada a tierra para líquidos a alta presión. La pistola debe conectarse a tierra a través de las conexiones de la manguera.
- Para las aparatos eléctricos — Debe conectarse el cable eléctrico a un circuito a tierra.
- Siempre enjuague la unidad dentro de un recipiente metálico separado, con la bomba a baja presión y habiendo sacado la boquilla rociadora. Sostenga la pistola firmemente contra el costado del recipiente para conectar a tierra el mismo y evitar chispas de estática.
- Siga las advertencias e instrucciones del fabricante del material y del solvente. Conozca los contenidos de las pinturas y los solventes con los que rocía. Lea todas las Hojas de Datos sobre Seguridad de Materiales (MSDS) y las etiquetas del contenedor provistas con las pinturas y los solventes. Siga las instrucciones de seguridad del fabricante de pinturas o solventes.
- Tenga muchísimo cuidado al usar materiales cuyo punto de ignición sea inferior a 70°F (21°C). El punto de inflamación es la temperatura a la que un fluido puede producir vapores suficientes para encenderse.
- El plástico puede causar chispas de estática. Nunca cuelgue plásticos para cerrar una zona a pintar. No use mantas plásticas al aplicar materiales inflamables.
- Use la presión más baja posible para enjuagar el equipo.
- No rocíe el ensamblaje de la bomba.





Información de seguridad importante • Lea toda la información de seguridad antes de operar el equipo. Guarde estas instrucciones.

PELIGRO: POSIBLE EXPLOSIÓN DEBIDO A MATERIALES INCOMPATIBLES



Causará daños materiales o lesiones graves.

PREVENCIÓN:

- No use materiales que contengan blanqueador o cloro.
- No use solventes de hidrocarburos halogenados como blanqueador, mohocida, cloruro de metileno y 1,1,1 tricloroetano. No son compatibles con el aluminio.
- Diríjase al proveedor de revestimientos para obtener los datos de compatibilidad del material con el aluminio.

PELIGRO: GENERAL

Puede causar daños materiales o lesiones graves.

PREVENCIÓN:

- Lea todas las instrucciones y las precauciones de seguridad antes de operar el equipo.
- Siga todos los códigos locales, estatales y nacionales correspondientes que rijan la ventilación, prevención de incendios y operación.
- Se han adoptado las normas de seguridad del Gobierno de los Estados Unidos según la Ley de seguridad ocupacional y salud (Occupational Safety and Health Act, OSHA). Deben consultarse estas normas, particularmente el apartado 1910 de las Normas generales y el apartado 1926 de las Normas de construcción.
- Utilice solamente componentes autorizados por el fabricante. El usuario asume todo riesgo y responsabilidad al utilizar componentes que no cumplan con las especificaciones mínimas y requisitos de seguridad del fabricante de la bomba.
- Todos los acopladores, las mangueras y las tapas de los filtros deben estar asegurados antes de operar la bomba de rocío. Las partes no aseguradas pueden ser expulsadas con gran fuerza o filtrar fluido a alta presión y provocar lesiones severas.
- Antes de cada uso, revise todas las mangueras en busca de cortes, fugas, abrasión o hinchazón de la cubierta. Revise si hay daños o movimiento de los acoplamiento. Cambie inmediatamente la manguera si existe alguna de estas condiciones. Nunca repare una manguera de pintura. Cámbiela por otra manguera conectada a tierra apta para alta presión.
- No retuerza ni doble la manguera en exceso. En la manguera airless pueden aparecer fugas a causa del desgaste, de retorcimientos o de un mal uso. Una fuga puede inyectar material en la piel.
- No exponga la manguera a temperaturas o presiones que superen las especificadas por el fabricante.
- No pinte en exteriores en días con viento.
- Use ropa que mantenga la pintura alejada de la piel y el cabello.
- No lo opere ni rocíe cerca de los niños. Mantenga a los niños alejados del equipo en todo momento.
- No se asome ni se pare sobre soportes inestables. Mantenga siempre la posición firme y el equilibrio efectivos.
- Use la presión más baja posible para enjuagar el equipo.
- Manténgase alerta y mire lo que hace.
- No utilice la unidad cuando se encuentre cansado o bajo la influencia de las drogas o el alcohol.
- Para las aparatos eléctricos — Desenchufe siempre el cable antes de trabajar en el equipo.
- No utilice la manguera como elemento de fuerza para tirar del equipo o levantarlo.
- No levantar por la manija del carro al cargar o descargando.

Instrucciones para conectar a tierra

Este producto se debe conectar a tierra. En caso de que ocurra un corto circuito, la conexión a tierra reduce el riesgo de choque eléctrico al proporcionar un alambre de escape para la corriente eléctrica. Este producto está equipado con un cable que tiene un alambre de conexión a tierra con un enchufe de conexión a tierra apropiado. El enchufe se debe enchufar en una toma de corriente que se haya instalado y conectado a tierra debidamente, de acuerdo con todos los códigos y estatutos locales.



La instalación incorrecta del enchufe a tierra puede ocasionar un riesgo de choque eléctrico.



Si es necesario reparar o cambiar el cable o el enchufe, no conecte el cable verde a tierra a ninguno de los terminales de espiga plana. El cable con aislamiento de color verde por fuera con o sin rayas amarillas es el alambre a tierra y debe conectarse a la espiga a tierra.

Consulte a un electricista o técnico de servicio capacitado si las instrucciones para la conexión a tierra no se entienden claramente o si tiene dudas en cuanto a que el producto esté debidamente conectado a tierra. No modifique el enchufe que se incluye. Si el enchufe no encaja en el receptáculo, pida a un electricista capacitado que instale un receptáculo adecuado.

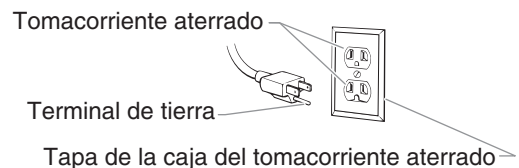

IMPORTANTE: Use solamente extensiones trifilares que tengan un enchufe de conexión a tierra de 3 hojas y un receptáculo de triple ranura que acepte el enchufe del producto. Asegúrese de que su extensión esté en buenas condiciones. Cuando use una extensión, asegúrese de usar una que sea lo suficientemente resistente como para soportar la corriente que descargue su producto. Un cable de un tamaño menor causará una caída de voltage en la línea que dará como resultado una pérdida de energía y un sobrecalentamiento. Se recomienda usar un cable de calibre 12. Si se utiliza un cable de extensión en el exterior, tiene que estar marcado con el sufijo W-A después de la designación del tipo de cable. Por ejemplo, SJTW-A para indicar que el cable es apropiado para uso en exteriores.

Parts List

Main Assembly

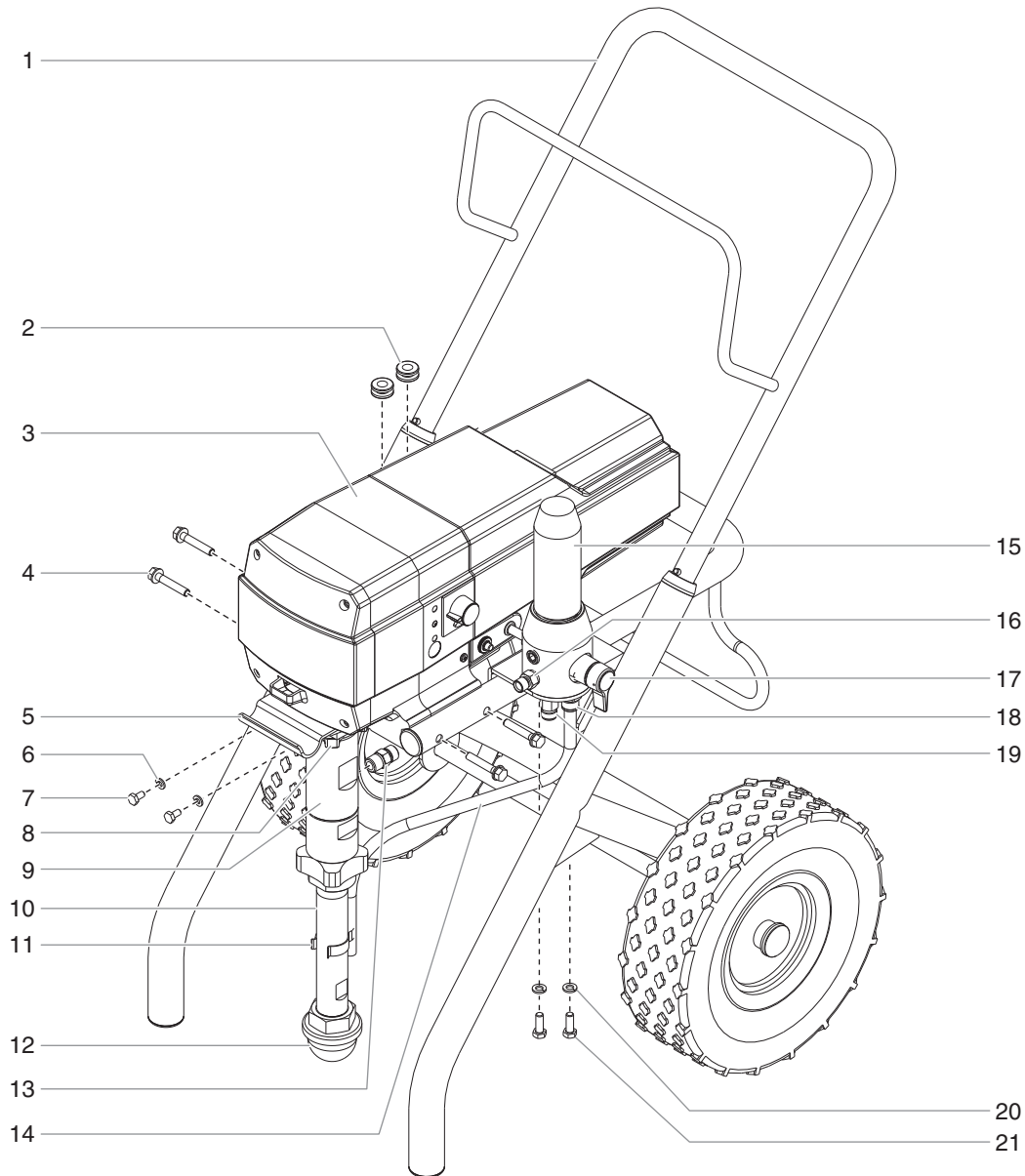

Item	Part #	Description	Quantity
1	800-600	Cart assembly.....	1
2	800-036	Grommet.....	2
3	-----	Drive assembly.....	1
4	761-178	Screw.....	4
5	800-324	Pail hook.....	1
6	763-551	Lock washer.....	2
7	858-625	Screw.....	2
8	800-328	Knock-off nut.....	1
9	800-300	Fluid section assembly.....	1
10	451-241	Siphon tube.....	1
11	730-334	Hose clamp.....	1

Item	Part #	Description	Quantity
12	710-046	Inlet screen.....	1
13	800-268	Fitting.....	1
14	800-904	Return hose.....	1
15	800-900	Filter assembly.....	1
16	812-003	Outlet fitting.....	1
17	800-915	PRIME/SPRAY valve assembly.....	1
18	800-269	Fitting.....	1
19	800-267	Fitting.....	1
20	860-002	Lock washer.....	2
21	860-535	Screw.....	2
22	800-266	Hose (not shown).....	1

Drive Assembly

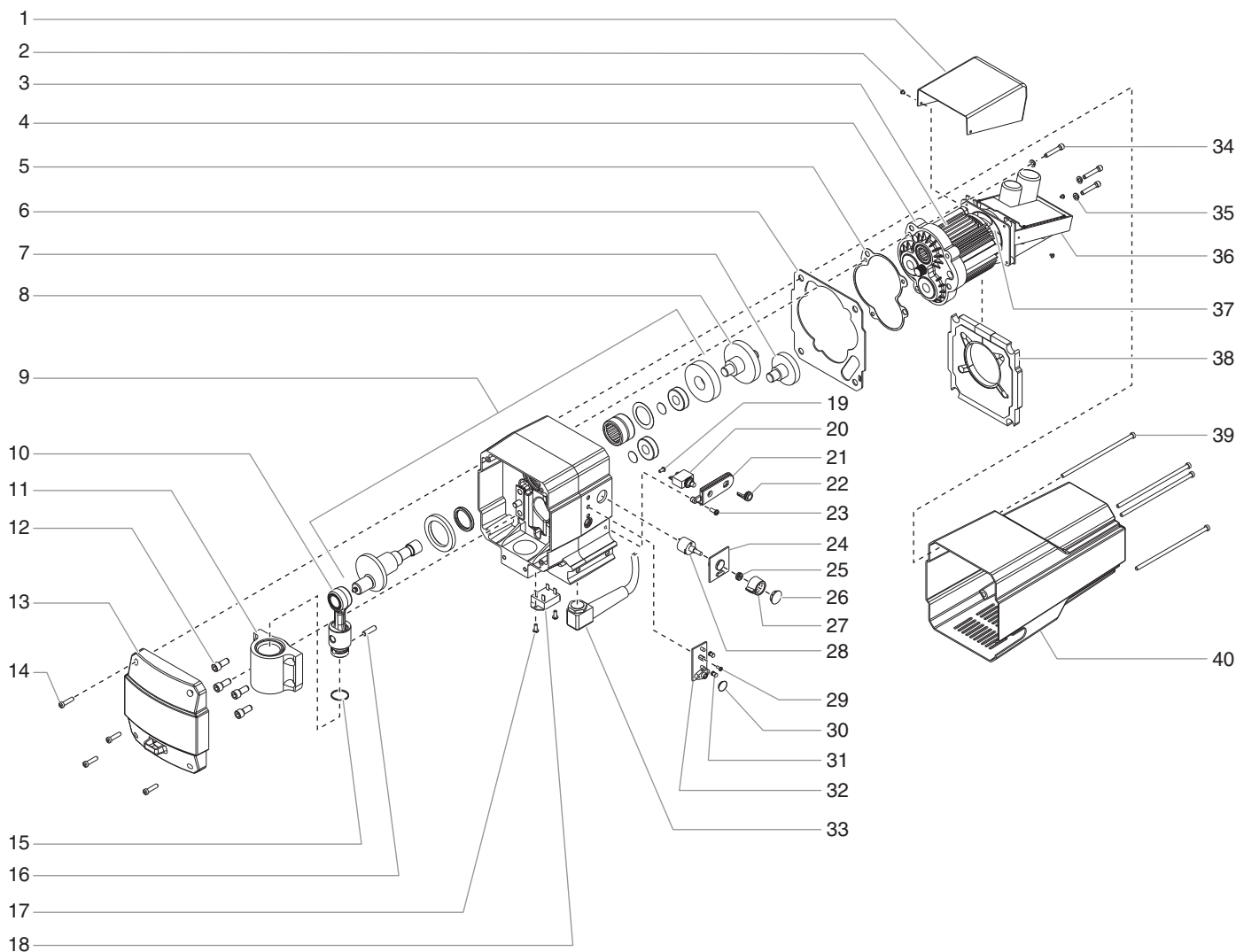

Item	Part #	Description	Quantity
1	800-078	Electronic cover	1
2	800-205	Screw	3
3	800-264	Motor assembly, 1.1 HP	1
4	800-256	Front end bell assembly	1
5	800-525	Housing gasket	1
6	800-541	Shroud gasket.....	1
7	800-261	1st stage gear assembly.....	1
8	800-262	2nd stage gear assembly	1
9	800-259	Front gearbox assembly).....	1
10	800-510	Slider assembly	1
11	800-253	Slider housing.....	1
12	700-283	Screw	4
13	800-265	Front cover with label	1
14	800-284	Screw	4
15	800-382	Retaining ring.....	1
16	800-753	Connecting pin.....	1
17	800-202	Screw	2
18	800-276	Relay.....	1
19	704-229	Screw	1
20	765-327	Circuit breaker	1
21	800-075	Mounting plate	1

Item	Part #	Description	Quantity
22	800-077	Grommet.....	1
23	800-076	Screw	1
24	800-274	Potentiometer mounting plate.....	1
25	700-176	Nut	1
26	700-175	Cap	1
27	700-159	Pressure control knob.....	1
28	800-277	Potentiometer	1
29	800-203	Screw	1
30	704-281	Port plug	1
31	800-043	LED cover	2
32	800-278	Indicator lights assembly	1
33	800-086	Power cord w/strain relief	1
34	700-287	Screw	3
35	763-551	Lock washer.....	3
36	800-297	Electronic control assembly.....	1
37	800-294	Fan assembly	1
38	800-435	Baffle assembly	1
39	800-283	Screw	4
40	800-254	Motor shroud w/labels	1
41	800-366	Wire cover, 7" (not shown)	1
42	800-368	Wire assembly (not shown)	1

NOTE: All electrical work should be performed by a Titan authorized service center.

Fluid Section Assembly (P/N 800-300)

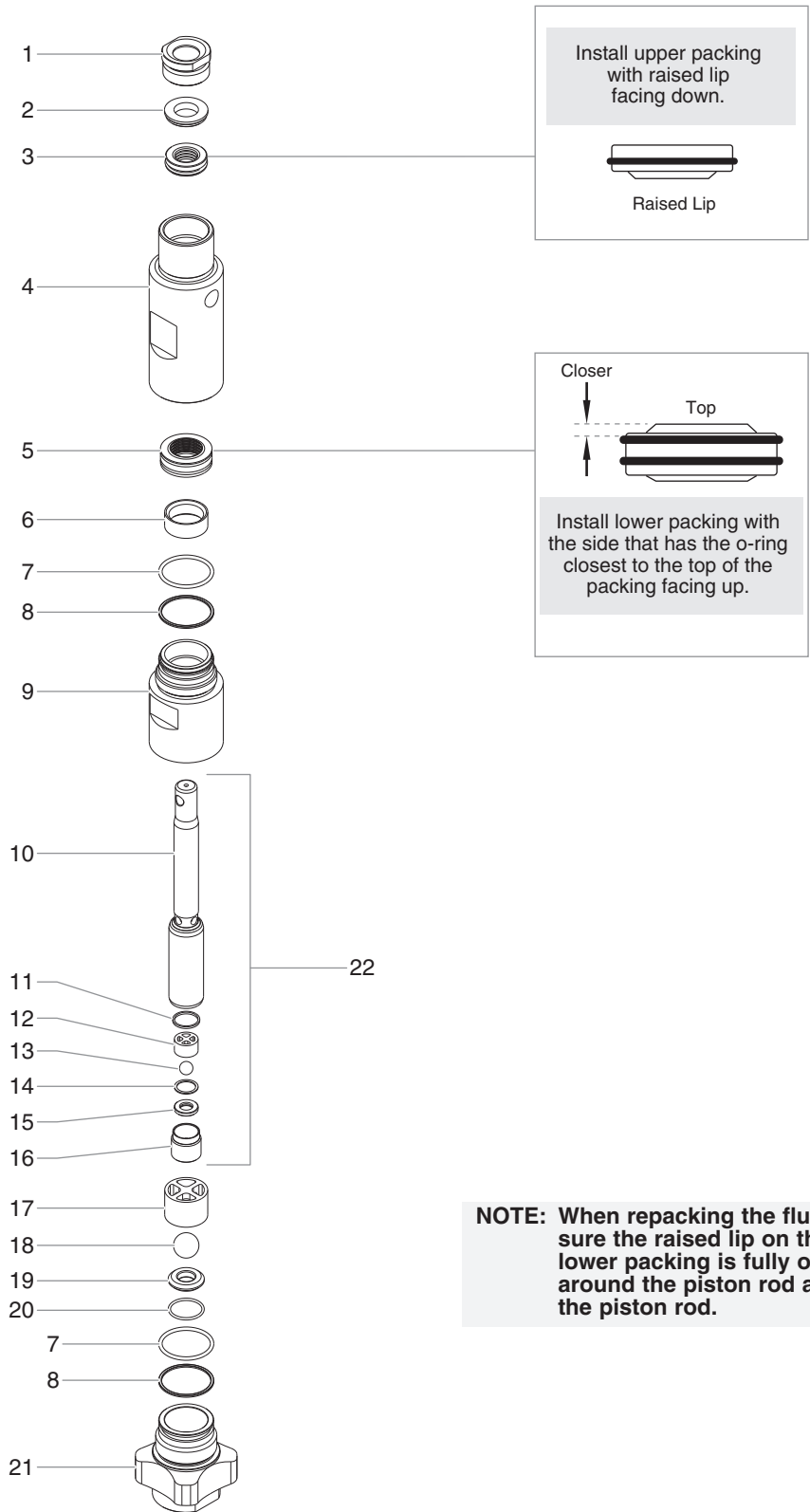

NOTE: When repacking the fluid section, make sure the raised lip on the bottom of the lower packing is fully outside the packing around the piston rod after insertion of the piston rod.

Item	Part #	Description	Quantity
1	800-325	Upper seal retainer	1
2	800-327	Spacer	1
3	800-248	Upper packing assembly	1
4	800-351	Upper housing	1
5	800-250	Lower packing assembly	1
6	800-354	Wear ring	1
7	800-332	O-ring, Viton.....	2
8	800-333	Back-up ring, Teflon.....	2
9	800-352	Lower housing	1
10	800-246	Piston rod.....	1
11	800-348	Outlet valve seal.....	1
12	800-244	Outlet valve cage.....	1
13	800-247	Outlet valve ball.....	1

Item	Part #	Description	Quantity
14	800-245	Washer, nylon	1
15	800-243	Outlet valve seat.....	1
16	800-336	Outlet valve retainer	1
17	800-322	Foot valve cage	1
18	800-242	Foot valve ball	1
19	800-241	Foot valve seat	1
20	762-058	O-ring.....	1
21	800-305	Foot valve housing	1
22	800-365	Piston assembly (includes items 10-16)....	1
	800-359	Lower packing insertion tool	
	800-273	Repacking kit (includes items 2, 3, 5-8, 11, 13, 14, 18, 20, and tool)	

High Rider Cart (P/N 800-600)

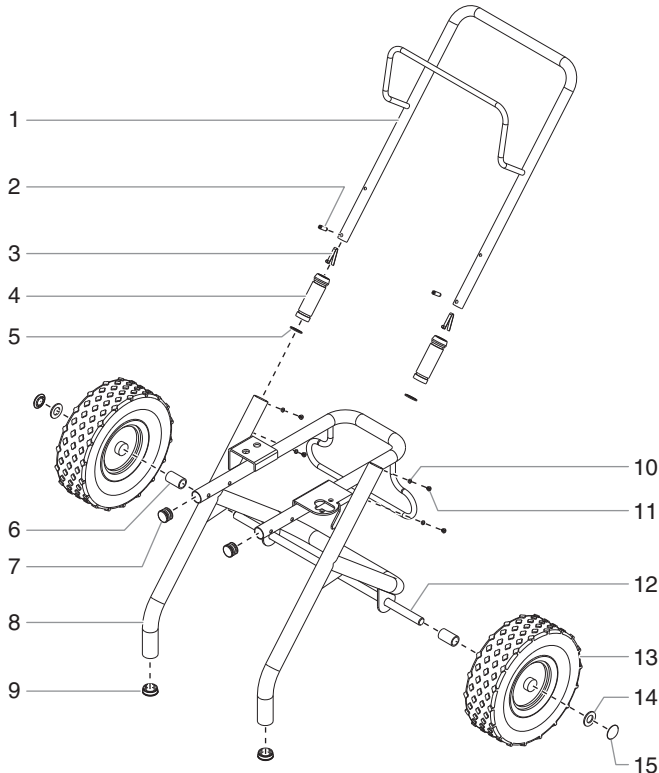

Item	Part #	Description	Quantity
1	800-280	Handle (includes items 2-5, 10, and 11)	1
2	590-508	Roll pin.....	2
3	590-507	Snap button	2
4	590-504	Sleeve.....	2
5	590-506	Washer.....	2
6	800-011	Spacer	2
7	710-199	Plug.....	2
8	800-279	Cart (includes items 7 and 9)	1
9	335-018	Plug.....	2
10	856-002	Washer.....	4
11	856-921	Screw.....	4
12	800-007	Axle.....	1
13	670-109	Wheel.....	2
14	870-004	Washer.....	2
15	800-019	Cap	2

Filter Assembly (P/N 800-900)

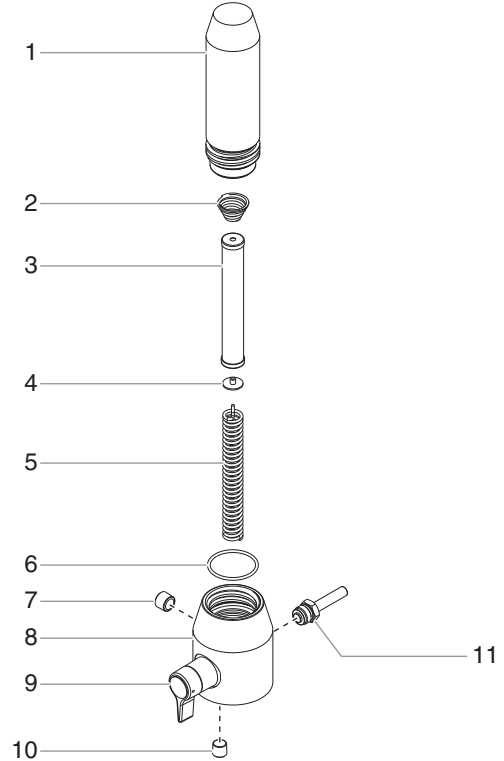

Item	Part #	Description	Quantity
1	800-905	Filter body	1
2	800-252	Filter spring.....	1
3	730-067	Filter, 60 mesh	1
4	702-251	Filter spring adapter.....	1
5	757-105	Core spring	1
6	800-906	O-ring, Teflon	1
7	800-908	Plug, 3/8"	1
8	800-901	Filter housing	1
9	800-915	PRIME/SPRAY valve assembly.....	1
10	800-907	Plug, 1/4"	1
11	800-437	Transducer.....	1

Siphon Set (low rider)

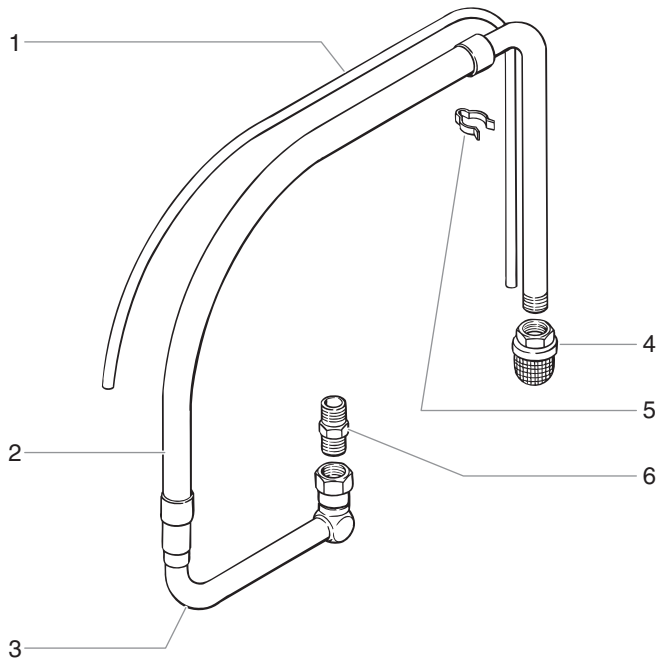

Item	Part #	Description	Quantity
1	800-903	Return hose	1
2	710-203	Siphon hose.....	1
3	710-195	Swivel	1
4	710-046	Inlet screen	1
5	730-334	Clamp	1
6	710-081	Siphon hose adapter	1
7	700-742	Tie wrap (not shown)	3
	710-204	Siphon hose assembly (includes items 2-6)	1

Labels

Part #	Description
313-1651	840i logo label
313-1673	Warning label (injection/explosion)
313-1847	Shock hazard label
313-1658	"Press to Reset" label
313-1848	Pressure control knob label
313-1867	Indicator lights label
313-1652	"Titan" front label
313-1906	Infinity logo label

Low Rider Cart (P/N 800-590)

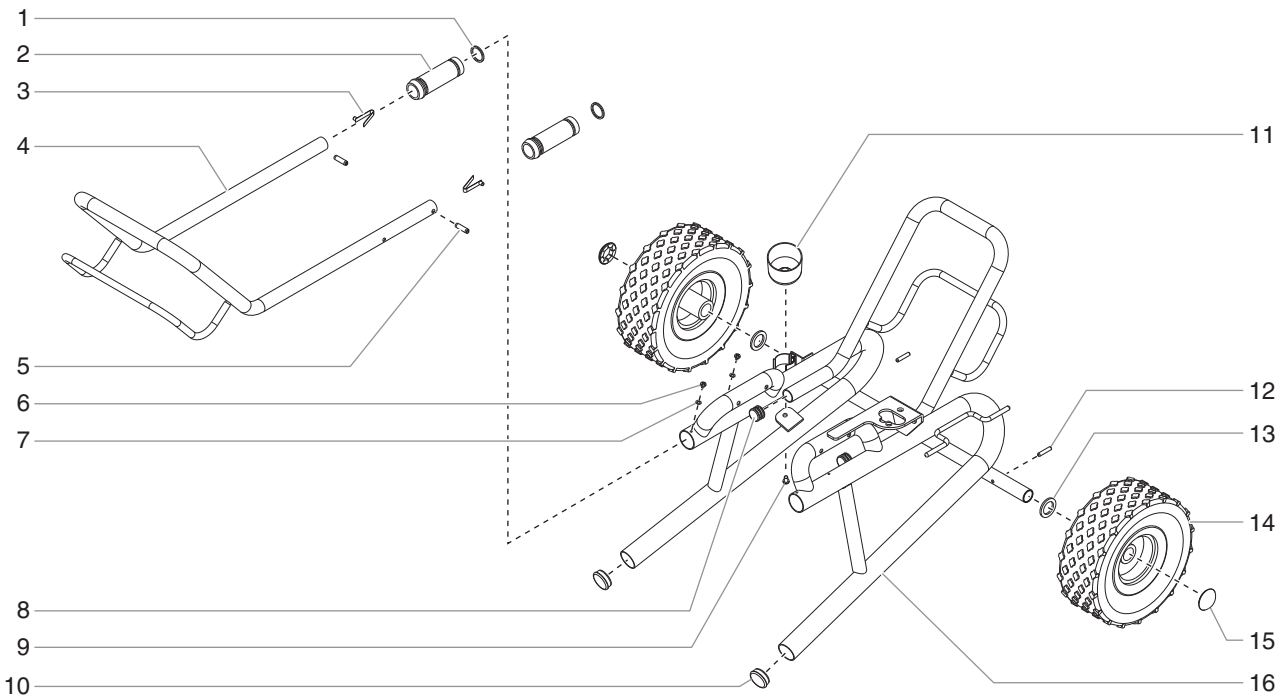

Item	Part #	Description	Quantity	Item	Part #	Description	Quantity
1	590-506	Washer.....	2	9	704-188	Screw	1
2	590-504	Sleeve.....	2	10	335-018	Plug.....	2
3	590-507	Snap button	2	11	700-1041	Drip cup	1
4	800-113	Handle assembly (includes items 1-3 and 5-7)	1	12	704-291	Roll pin.....	2
5	590-508	Roll pin.....	2	13	800-109	Wheel spacer.....	2
6	856-921	Screw.....	4	14	800-593	Wheel.....	2
7	856-002	Washer.....	4	15	800-111	Cap	2
8	700-674	Plug.....	2	16	800-112	Cart weldment (includes items 8 and 10)...	1

PRIME/SPRAY Valve Assembly (P/N 800-915)

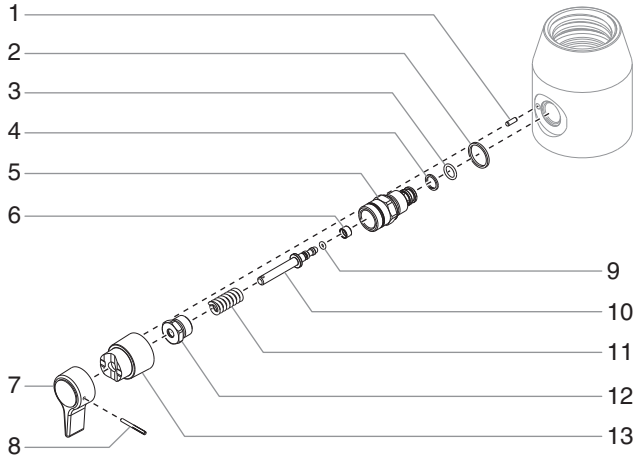

Item	Part #	Description	Quantity
1	700-823	Dowel pin	1
2	700-537	Gasket	1
3	222-012	O-ring, Teflon	1
4	221-012	O-ring, Viton	1
5	700-253	Valve housing	1
6	800-910	Valve seat	1
7	700-697	Valve handle	1
8	700-759	Groove pin	1
9	700-721	O-ring, Viton	1
10	700-250	Valve stem	1
11	800-926	Spring	1
12	700-248	Valve retainer	1
13	700-251	Cam base	1

Accessories

Airless Tip Selection

Tips are selected by the orifice size and fan width. The proper selection is determined by the fan width required for a specific job and by the orifice size that will supply the desired amount of fluid and accomplish proper atomization.

For light viscosity fluids, smaller orifice tips generally are desired. For heavier viscosity materials, larger orifice tips are preferred. Please refer to the chart below.

NOTE: Do not exceed the sprayer's recommended maximum tip size.

The following chart indicates the most common sizes and the appropriate materials to be sprayed.

Tip Size	Spray Material	Filter Type
.011 — .013	Lacquers and stains	100 mesh filter
.015 — .019	Oil and latex	60 mesh filter
.021 — .026	Heavy bodied latex and blockfillers	30 mesh filter

Fan widths measuring 8" to 12" (20 to 30 cm) are preferred because they offer more control while spraying and are less likely to plug.

Liquid Shield Plus

Cleans and protects spray systems against rust, corrosion and premature wear.

Part No.	Description
314-483	4 ounce bottle
314-482	1 quart bottle

Piston Lube

Specially formulated to prevent materials from adhering to the piston rod, which becomes abrasive to the upper seals. Piston Lube will break down any material that may accumulate in the wet cup and keep it from drying.

Part No.	Description
314-481	4 ounce bottle
314-480	8 ounce bottle

Miscellaneous

Part No.	Description
490-012	Hose coupling, 1/4" x 1/4"
730-397	High pressure fluid Gauge
314-171	Lubriplate, 14 ounce individual
314-172	Lubriplate, 6 lb. can

Electrical Schematic

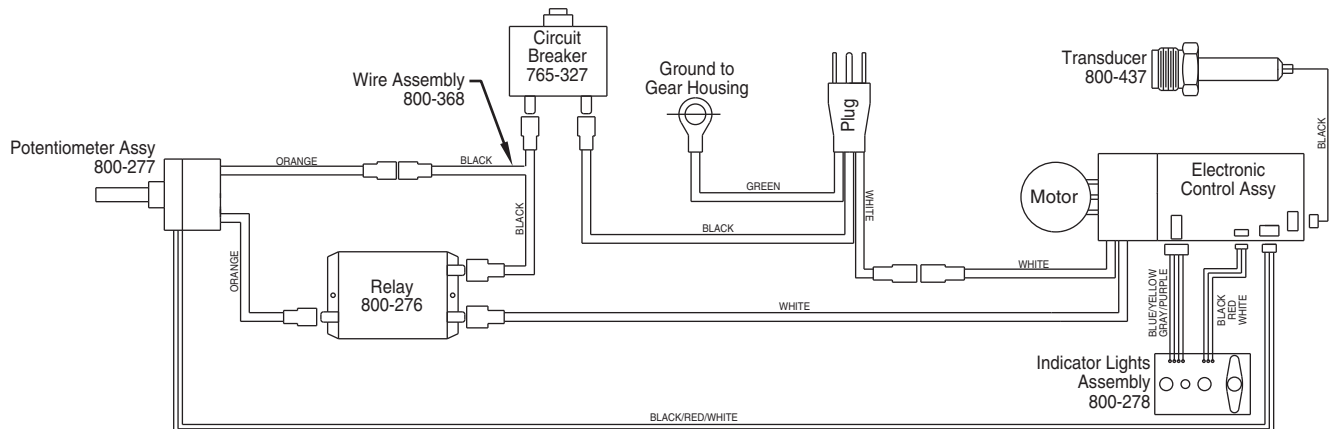

NOTE: All electrical work should be performed by a Titan authorized service center.

Warranty

Titan Tool, Inc., ("Titan") warrants that at the time of delivery to the original purchaser for use ("End User"), the equipment covered by this warranty is free from defects in material and workmanship. Titan's obligation under this warranty is limited to replacing or repairing without charge those parts which, to Titan's reasonable satisfaction, are shown to be defective within twenty-five (25) months after sale to the End User. This warranty applies only when the unit is installed and operated in accordance with the recommendations and instructions of Titan.

This warranty does not apply in the case of damage or wear caused by abrasion, corrosion or misuse, negligence, accident, faulty installation, substitution of non-Titan component parts, or tampering with the unit in a manner to impair normal operation.

Defective parts are to be returned to an authorized Titan sales/service outlet. All transportation charges, including return to the factory, if necessary, are to be borne and prepaid by the End User. Repaired or replaced equipment will be returned to the End User transportation prepaid.

THERE IS NO OTHER EXPRESS WARRANTY. TITAN HEREBY DISCLAIMS ANY AND ALL IMPLIED WARRANTIES INCLUDING, BUT NOT LIMITED TO, THOSE OF MERCHANTABILITY AND FITNESS FOR A PARTICULAR PURPOSE, TO THE EXTENT PERMITTED BY LAW. THE DURATION OF ANY IMPLIED WARRANTIES WHICH CANNOT BE DISCLAIMED IS LIMITED TO THE TIME PERIOD SPECIFIED IN THE EXPRESS WARRANTY. IN NO CASE SHALL TITAN LIABILITY EXCEED THE AMOUNT OF THE PURCHASE PRICE. LIABILITY FOR CONSEQUENTIAL, INCIDENTAL OR SPECIAL DAMAGES UNDER ANY AND ALL WARRANTIES IS EXCLUDED TO THE EXTENT PERMITTED BY LAW.

TITAN MAKES NO WARRANTY AND DISCLAIMS ALL IMPLIED WARRANTIES OF MERCHANTABILITY AND FITNESS FOR A PARTICULAR PURPOSE WITH RESPECT TO ACCESSORIES, EQUIPMENT, MATERIALS OR COMPONENTS SOLD BUT NOT MANUFACTURED BY TITAN. THOSE ITEMS SOLD, BUT NOT MANUFACTURED BY TITAN (SUCH AS GAS ENGINES, SWITCHES, HOSES, ETC.) ARE SUBJECT TO THE WARRANTY, IF ANY, OF THEIR MANUFACTURER. TITAN WILL PROVIDE THE PURCHASER WITH REASONABLE ASSISTANCE IN MAKING ANY CLAIM FOR BREACH OF THESE WARRANTIES.

Material Safety Data Sheets (MSDS) are available on Titan's website or by calling Customer Service.



United States Sales & Service

Tech Service/Order Entry: 1-800-526-5362
Fax (Order Entry): 1-800-528-4826
Fax (Tech Service): 1-800-525-9501

1770 Fernbrook Lane
Minneapolis, MN 55447
www.titantool.com

Canadian Branch

Phone: 1-800-565-8665
Fax: 1-800-856-8496

200 Trowers Road, Unit 7B
Woodbridge, Ontario L4L 5Z8

International

Phone: 1-201-337-1240
Fax: 1-201-405-7449

1770 Fernbrook Lane
Minneapolis, MN 55447